

S711

Soft starter



All brand and product names are trademarks or registered trademarks of their respective owners.

### **Service**

For service and support, please contact your local sales organization.

[Eaton.com/contacts](https://www.eaton.com/contacts)

[Eaton.com/aftersales](https://www.eaton.com/aftersales)

### **For customers in US/Canada contact:**

#### **EatonCare Customer Support Center**

Call the EatonCare Support Center if you need assistance with placing an order, stock availability or proof of shipment, expediting an existing order, emergency shipments, product price information, returns other than warranty returns, and information on local distributors or sales offices.

Voice: 877-ETN-CARE (386-2273) (8:00 a.m. – 6:00 p.m. EST)

After-Hours Emergency: 800-543-7038 (6:00 p.m. – 8:00 a.m. EST)

#### **Drives Technical Resource Center**

Voice: 877-ETN-CARE (386-2273) option 2, option 6

(8:00 a.m. – 5:00 p.m. Central Time U.S. [UTC-6])

email: [TRCDrives@Eaton.com](mailto:TRCDrives@Eaton.com)

page: [Eaton.com/drives](https://www.eaton.com/drives)

### **Original operating manual**

The English-language edition of this document is the original operating manual.

### **Translation of the original operating manual**

All editions of this document other than those in English language are translations of the original operating manual.

1. Edition 2025, publication date 03/25

See revision protocol in the "About this manual" chapter

© 2025 by Eaton Industries GmbH, 53105 Bonn

All rights, including those of translation, reserved.

No part of this manual may be reproduced, stored in a retrieval system, or transmitted in any form or by any means, electronic, mechanical, photocopying, micro-filming, recording or otherwise, without the prior written permission of Eaton Industries GmbH, Bonn.

Subject to alteration.



## **Danger!** **Dangerous electrical voltage!**

### **Before commencing the installation**

- Disconnect the power supply from the device
- Ensure that devices cannot be accidentally retriggered.
- Verify isolation from the supply.
- Ground and short-circuit.
- Cover or enclose neighbouring units that are live.
- Follow the engineering instructions (IL) of the device concerned.
- Only suitably qualified personnel in accordance with EN 50110-1/-2 (VDE 0105 Part 100) may work on this device/system.
- Before installation and before touching the device ensure that you are free of electrostatic charge.
- The functional earth (FE) must be connected to the protective earth (PE) or to the potential equalizing.  
The system installer is responsible for implementing this connection.
- Connecting cables and signal lines should be installed so that inductive or capacitive interference do not impair the automation functions.
- Install automation devices and related operating elements in such a way that they are well protected against unintentional operation.
- Suitable safety hardware and software measures should be implemented for the I/O connection so that a cable or wire breakage on the signal side does not result in undefined states in the automation device.
- Ensure a reliable electrical isolation of the low voltage for the 24 V supply. Only use power supply units complying with IEC 60364-4-41 or HD 384.4.41 S2 (VDE 0100 part 410).
- Deviations of the mains voltage from the nominal value must not exceed the tolerance limits given in the technical data, otherwise this may cause malfunction and dangerous operation.
- Emergency-Stop devices complying with IEC/EN 60204-1 must be effective in all operating modes of the automation devices. Unlatching the emergency switching off devices must not cause restart.
- Built-in devices for enclosures or cabinets must only be run and operated in an installed state, desk-top devices or portable devices only when the housing is closed.
- Measures should be taken to ensure the proper restart of programs interrupted after a voltage dip or failure. This should not cause dangerous operating states even for a short time. If necessary, emergency switching off devices should be implemented.
- Wherever faults in the automation system may cause damage to persons or property, external measures must be implemented to ensure a safe operating state in the event of a fault or malfunction (for example, by means of separate limit switches, mechanical interlocks, etc.).
- During operation, and depending on their degree of protection, soft starters may have live, uninsulated, moving, and/or rotating parts, as well as hot surfaces.
- The impermissible removal of the required cover, improper installation or incorrect operation of the motor or soft starter can cause the failure of the device and serious injury and/or material damage.
- Comply with all applicable national accident prevention regulations (e.g. BGV A3) when working with energized soft starters.
- The electrical installation must be carried out in accordance with the relevant regulations (e.g. with regard to cable cross sections, fuses, PE).
- All transport, installation, commissioning and maintenance work must only be carried out by trained personnel (observe IEC 60364, HD 384 or DIN VDE 0100 and national accident prevention regulations).
- If applicable, systems in which soft starters are installed must be equipped with additional monitoring and protective devices in accordance with the applicable safety regulations, e.g., the German Equipment and Product Safety Act, accident prevention regulations, etc. Making changes to the soft starters by using the operating software is allowed.
- Keep all covers and doors closed during operation.
- When designing the machine, the user must incorporate mechanisms and measures that limit the consequences of a drive controller malfunction or failure (an increase in motor speed or the motors sudden stop) so as to prevent hazards to people and property, e.g.:
  - Additional stand-alone devices for monitoring parameters that are relevant to safety (speed, travel, end positions, etc.)
  - Electrical and non-electrical safety devices (interlocks or mechanical locks) for mechanisms that protect the entire system
  - Due to the possibility of there being capacitors that are still holding a charge, do not touch live device parts or terminals immediately after disconnecting the soft starters from the supply voltage. Heed the corresponding labels on the soft starters.

# Contents

<b>0</b>	<b>About this manual</b> .....	<b>9</b>
0.1	Target audience .....	9
0.2	List of revisions.....	9
0.3	Related documents.....	10
0.4	Writing conventions .....	11
0.4.1	Helpful notes and tips .....	11
0.4.2	Hazard cautions of equipment damage .....	11
0.4.3	Hazard warnings of personal injury or death .....	11
0.4.4	Instructions.....	11
0.4.5	Graphics .....	11
0.5	Acronyms and abbreviations .....	12
0.6	Mains supply voltages .....	13
0.7	Units of measurement .....	13
<b>1</b>	<b>S711 series</b> .....	<b>14</b>
1.1	Introduction.....	14
1.2	Intended use.....	14
1.3	Maintenance and inspection .....	15
1.4	Storage .....	15
1.5	Service and warranty .....	16
<b>2</b>	<b>Caution statements</b> .....	<b>17</b>
2.1	Electrical shock risk .....	18
2.2	Unexpected operation.....	19
2.3	Motor overload memory.....	20
2.4	FCC Class A device .....	20
2.5	Avertissements à l'attention des clients canadiens .....	21
<b>3</b>	<b>System design</b> .....	<b>24</b>
3.1	Feature list.....	24
3.2	Model code.....	25
3.3	Model selection .....	26
3.3.1	Starter sizing .....	26
3.3.2	AC-53b/AC-3b format (bypassed current rating) .....	26
3.4	Current ratings.....	27
3.4.1	IEC ratings .....	27
3.4.2	NEMA motor ratings .....	29
3.5	Dimensions and weights .....	31
3.6	Physical installation.....	37
3.7	Accessories .....	38
3.7.1	Communication cards .....	38
3.7.2	Keypad.....	38
3.7.3	Finger protection kit .....	38
3.7.4	S711 Connect app.....	38
3.8	Main contactor or circuit breaker .....	39

3.9	Power factor correction.....	39
3.10	Short circuit protection devices (SCPD) .....	40
3.11	IEC coordination with short circuit protection devices .....	40
3.11.1	Type 1 coordination .....	40
3.11.2	Type 2 coordination .....	40
3.11.3	IEC coordination with short circuit protection devices .....	41
3.12	UL coordination with short circuit protection devices .....	42
3.12.1	Standard fault short circuit .....	42
3.12.2	High fault short circuit.....	43
3.13	Specifications.....	44
3.13.1	Supply.....	44
3.13.2	Short circuit capability .....	44
3.13.3	Radio and electromagnetic capability .....	44
3.13.4	Inputs .....	44
3.13.5	Outputs .....	44
3.13.6	Environmental .....	45
3.13.7	Heat dissipation .....	45
3.13.8	Motor overload protection.....	45
3.13.9	Operational life (internal bypass contacts) .....	45
3.13.10	Accuracy .....	45
3.14	Certifications .....	46
3.15	Disposal instructions.....	46
<b>4</b>	<b>Installation .....</b>	<b>47</b>
4.1	Command source .....	47
4.2	Setup procedure .....	48
4.3	Inputs .....	50
4.3.1	Input terminals.....	50
4.3.2	Motor thermistor .....	51
4.3.3	Enable/Reset.....	51
4.3.4	Start/stop .....	52
4.3.5	Programmable digital inputs.....	53
4.4	Outputs .....	53
4.4.1	Output terminals.....	53
4.4.2	Main contactor output.....	54
4.4.3	Programmable relay outputs.....	55
4.5	Control voltage .....	55
4.6	On-board Modbus RTU.....	56
4.7	Power terminations .....	57
4.7.1	Wiring connectors .....	59
4.8	Motor connection .....	60
4.8.1	In-line installation, internally bypassed.....	60
4.8.2	Inside delta installation, internally bypassed.....	61
4.9	Earth terminations.....	62
4.10	Typical installation .....	63
4.10.1	Internally bypassed installation .....	63

<b>5</b>	<b>Keypad and feedback</b> .....	<b>64</b>
5.1	The keypad .....	64
5.2	Removable keypad .....	65
5.3	Status LEDs .....	66
5.4	Menu map .....	67
5.5	Displays .....	68
5.5.1	Welcome.....	68
5.5.2	Starter status.....	68
5.5.3	Phase currents .....	68
5.5.4	Last start information .....	68
5.5.5	User configurable screen .....	69
5.5.6	Performance graph.....	69
<b>6</b>	<b>Tools</b> .....	<b>70</b>
6.1	Pair Bluetooth .....	70
6.2	Output signal test .....	71
6.3	Digital input state .....	72
6.4	Relay output state.....	72
6.5	Thermistor reset .....	73
6.6	Reset motor overload.....	73
6.7	Simulation mode .....	74
<b>7</b>	<b>Quick setup</b> .....	<b>76</b>
<b>8</b>	<b>Load/save settings</b> .....	<b>77</b>
<b>9</b>	<b>Logs and info</b> .....	<b>78</b>
9.1	Event log.....	78
9.2	Counters .....	78
9.3	About screen .....	79
9.3.1	Serial number and rating.....	79
9.3.2	Parameter list.....	79
9.3.3	Keypad.....	79
9.3.4	Starter .....	79
9.3.5	Bootloader starter.....	79
9.3.6	Communication card.....	80
9.3.7	Bootloader communication card.....	80
<b>10</b>	<b>Factory Reset</b> .....	<b>81</b>
<b>11</b>	<b>Cybersecurity</b> .....	<b>82</b>
11.1	Starter defence in depth .....	82
11.2	Plant security .....	82
11.3	Network security.....	82
11.4	System integrity .....	83
11.4.1	PIN number protection.....	83
11.4.2	Digitally signed firmware.....	84
11.4.3	Secure Bluetooth pairing .....	84
11.5	Firmware updates.....	84
11.6	Vulnerabilities .....	84

11.6.1	Decommissioning guidelines .....	84
<b>12</b>	<b>Operation .....</b>	<b>85</b>
12.1	Start, stop and reset commands .....	85
12.2	Command override .....	85
12.3	Two-phase control.....	86
12.4	Fire mode .....	87
12.5	External fault.....	88
12.6	Typical control methods .....	89
12.7	Soft start methods.....	90
12.7.1	Constant current .....	90
12.7.2	Constant current with current ramp .....	91
12.7.3	Constant current with kickstart.....	92
12.7.4	Timed voltage ramp .....	93
12.7.5	Pump control for starting.....	94
12.8	Stop methods .....	95
12.8.1	Coast to stop .....	95
12.8.2	Timed voltage ramp soft stop .....	95
12.8.3	Pump control for stopping.....	96
12.8.4	DC brake .....	98
12.8.5	Soft brake .....	100
12.9	Reverse direction operation .....	102
12.10	Jog operation.....	104
12.11	Inside delta operation .....	106
12.12	Secondary motor set.....	107
<b>13</b>	<b>Programmable parameters .....</b>	<b>108</b>
13.1	User Parameters menu .....	108
13.2	PIN number (password) protection .....	108
13.3	Altering parameter values .....	109
13.4	Locking parameters.....	109
13.5	Parameter list versions .....	110
13.6	Parameter list.....	111
13.7	P1 User Configuration.....	115
13.8	P2 Motor Details .....	117
13.9	P3 Motor Start/Stop 1.....	119
13.10	P4 Motor Start/Stop 2.....	122
13.11	P5 Motor Protections.....	125
13.12	P6 Starter Protections .....	130
13.13	P7 Digital Inputs.....	132
13.14	P8 Relay Outputs .....	135
13.15	P9 Display.....	137
13.16	P10 Fieldbus .....	140
13.17	P20 Advanced .....	142

<b>14</b>	<b>Troubleshooting .....</b>	<b>146</b>
14.1	Protection responses.....	146
14.2	Fault messages .....	147
14.3	General faults.....	151
14.4	Starter LEDs .....	153
<b>15</b>	<b>Appendix .....</b>	<b>154</b>
15.1	Modbus RTU register map .....	154
15.1.1	Register map summary.....	154
15.1.2	Command register.....	155
15.1.3	Starter about info .....	156
15.1.4	Real-time data .....	157
15.1.5	Counters .....	158
15.1.6	User parameters .....	159
15.2	Fault codes .....	163
15.3	User parameter settings .....	165

## 0 About this manual

This manual contains specific information that will enable you to select an S711 soft starter, connect it, and use its parameters to configure it as required for your specific needs if necessary. The manual applies to all S711 soft starter models.

This manual is intended for use with soft starters using firmware versions 01.00/01.00.

### 0.1 Target audience

This manual is intended for engineers and electricians. Electrical related knowledge and skills are required to commission and integrate this product successfully.

We assume that you have appropriate electrical qualifications and knowledge of local electrical regulations in order to achieve this in a safe and professional manner.

### 0.2 List of revisions

The following significant amendments have been introduced since previous issues:

Publication date	Page	Keyword	new	modified	deleted
03/25		Initial issue	✓		

0 About this manual

0.3 Related documents

### 0.3 Related documents

For further information, see the following documentation:

- MN039004EN  
S711 Soft Starter - Communication Manual
- MN039005EN  
S711 Connect App Instructions
- IL039001ZU  
Instruction Leaflet for S711 Frame size 1-2-3-4
- IL039003ZU  
Instruction Leaflet for S711 Communication cards  
(S711-NET-PROFINET-2, S711-NET-ETHERNET-2,  
S711-NET-MODBUSTCP-2)
- IL039004ZU  
Instruction Leaflet for S711 Keypad (S711-KEY-LCD)

You can find the above-mentioned documents as well as this manual as a PDF document at: [Eaton.com/documentation](https://www.eaton.com/documentation)



Enter "S711" or the document number (eg "MN039007EN") as the search term in the Quick search text field.

Current information on the product can be obtained from the Drives section via the link: [Eaton.com/S711](https://www.eaton.com/S711)

## 0.4 Writing conventions

Symbols used in this manual have the following meanings:

### 0.4.1 Helpful notes and tips

 Provides helpful information.

### 0.4.2 Hazard cautions of equipment damage

	<b>CAUTION</b> Indicates a hazard that may damage the equipment or installation.
---	---

### 0.4.3 Hazard warnings of personal injury or death

	<b>WARNING</b> Indicates a hazard that may cause personal injury or death.
---	---

### 0.4.4 Instructions

In procedures, instructions to be followed are numbered as 1., 2., 3., etc.

### 0.4.5 Graphics

Graphics include captions such as **1**, **2**, **3**, etc to refer to the different components in the graphic. These icons are then repeated in a caption table below the graphic, with a description of the corresponding item.

## 0 About this manual

### 0.5 Acronyms and abbreviations

#### 0.5 Acronyms and abbreviations

The following acronyms and abbreviations are used in this manual:

<b>Acronym / Abbreviation</b>	<b>Definition</b>
A	Ampere
AC	Alternating current
accel.	Acceleration
AWG	American wire gauge
BLE	Bluetooth Low Energy
Cmd	Command
ComCard	Communication card
Curr	Current
DC	Direct current
decel.	Deceleration
DHCP	Dynamic host configuration protocol
DI	Digital input
DOL	Direct on line
EC	European Commission
EU	European Union
Ex.	Excess
Ext	External
FLA	Full load amperage
FLT	Full load torque
HP	Horsepower
HRC fuse	High rupturing capacity fuse
IEC	International Electrotechnical Commission
Imbal	Imbalance
IO	Input/output
kA	Kiloampere
kW	Kilowatt
LED	Light emitting diode
MC	Microcontroller
MCCB	Moulded case circuit breaker
mm	Millimetre
NC	Normally closed
NEC	National Electrical Code
NEMA	National Electrical Manufacturers Association
Nm	Newton metre
NO	Normally open
OL	Overload
Param	Parameter
PCB	Printed circuit board
pf	Power factor
PIN	Personal identification number
PLC	Programmable logic controller
RAM	Random-access memory
recip	Reciprocating
SCPD	Short circuit protection device
SCR	Silicon-controlled rectifier, also known as thyristor
(SCR) I <sub>tsm</sub>	Surge (non-repetitive) on-state current

Acronym / Abbreviation	Definition
Therm	Thermistor
TVR	Timed voltage ramp
UL	Underwriters Laboratories
V	Volt
V AC	Volts alternating current
V DC	Volts direct current
VZC	Voltage zero crossing

## 0.6 Mains supply voltages

See Specifications on page 44.

## 0.7 Units of measurement

Every physical dimension included in this manual uses international metric system units, otherwise known as SI units (Système International d'Unités).

For the purpose of the equipment's UL certification, some of these dimensions are accompanied by their equivalents in imperial units.

Table 1: Units of measurement

Designation	SI value	Imperial unit	Conversion value	US-American designation
Length	25.4 mm	1 in (")	0.0394	inch
Power	0.7457 kW	1 HP = 1.014 PS	1.341	horsepower
Torque	0.113 Nm	1 lbf in	8.851	pound-force inches
Temperature	-17.222 °C (T <sub>C</sub> )	1 °F (T <sub>F</sub> )	$T_F = T_C \times 9/5 + 32$	Fahrenheit
Weight	0.4536 kg	1 lb	2.205	pound
Flow rate	1.698 m <sup>3</sup> /min	1 cfm	0.588	cubic feet per minute

## 1 S711 series

### 1.1 Introduction

## 1 S711 series

### 1.1 Introduction

The S711 series offers a range of soft starters, from 12 A to 560 A. All soft starters are internally bypassed.

### 1.2 Intended use

The S711 soft starters are not domestic appliances. They are designed only for industrial use, as system components.

The S711 soft starters are electrical devices for controlling three-phase motors. They are designed for installation in machines or for use in combination with other components within a machine or system.

If the soft starter is installed in a machine, you must not place it into operation until it has been determined that the corresponding machine meets the safety and protection requirements set forth in Machinery Regulation (EU) 2023/1230. The user is responsible for ensuring the machine application's compliance with European Union (EU) regulations and directives.

The CE marking on S711 soft starters confirms that the devices, when used in a typical soft starter configuration, comply with the EU's Low Voltage, RED, EMC and RoHS directives (LVD 2014/35/EU, RED 2014/53/EU, EMC 2014/30/EU, RoHS 2011/65/EU).

When used with the described system configuration, S711 soft starters are suitable for use with public and private electrical power networks.

You can only connect the S711 to an IT network (network without a direct connection to earth potential) under certain conditions, as the device's internal filter capacitors will connect the network to earth potential (enclosure).

In unearthed networks, this can result in hazardous situations or damage to the device (insulation monitoring is required).

If testing the soft starter with a small motor, it must draw at least 10% of the starter's programmed FLA setting on each phase.



#### **WARNING**

Do not do the following at the S711 soft starter's output (terminals T1, T2, T3):

- connect a voltage or capacitive loads (eg phase compensation capacitors)
- connect multiple S711 soft starters to each other in parallel
- make a direct connection to the input (bypass)

## 1.3 Maintenance and inspection



Always observe the technical data and connection conditions.

The relevant information about the S711 soft starter can be found on its nameplate and in the related documentation. Any other use will be considered to be an improper use of the device.

### 1.3 Maintenance and inspection

S711 soft starters are maintenance-free, provided that the general rating data, as well as the technical data for the specific models in use, is observed.

However, external influences can affect the soft starter's operation and lifespan.

Because of this, we recommend inspecting the devices on a regular basis and carrying out the following maintenance activities at the specified intervals.

Table 2: Recommended maintenance activities for S711 soft starters

Maintenance measures	Maintenance interval
Clean cooling vents (cooling slits)	As needed
Check that the fan is working properly	6 - 24 months (depending on the environment)
Check the filter in the control panel doors (see the manufacturer's specifications)	6 - 24 months (depending on the environment)
Check all ground connections to make sure they are intact	On a regular basis, at periodic intervals
Check the tightening torques of the connections (control signal terminals, power terminals)	On a regular basis, at periodic intervals
Check connection terminals and all metallic surfaces for corrosion	6 - 24 months; when stored, no more than 12 months later (depending on the environment)
Motor cables and shield connection (EMC)	According to manufacturer specifications, no later than 5 years

The S711 is generally repairable, provided the damage is economic to repair. Please contact your local supplier for repair enquiries.

Dispose of the device according to the applicable environmental laws and provisions for the disposal of electrical or electronic devices.

### 1.4 Storage

If the S711 is stored before use, ensure suitable ambient conditions at the site of storage:

- Storage temperature: -40 ~ +70 °C (+70 °C < 24 hours)
- Relative average air humidity: < 95 %, non-condensing (EN 61800-5-1)

## 1 S711 series

### 1.5 Service and warranty

#### **1.5 Service and warranty**

In the unlikely event that you experience a problem with your S711 soft starter, please contact your local supplier.

When you call, have the following data ready:

- the soft starter's exact part number (refer to the nameplate)
- the serial number (refer to the nameplate)
- the date of purchase
- a detailed description of the problem that occurred when running the soft starter

If some of the information printed on the nameplate is not legible, please state only the data that is clearly legible.

Information concerning the warranty can be found in the Terms and Conditions Eaton Industries GmbH.

## 2 Caution statements

Caution statements cannot cover every potential cause of equipment damage but can highlight common causes of damage. It is the installer's responsibility to read and understand all instructions in this manual prior to installing, operating or maintaining the equipment, to follow good electrical practice including applying appropriate personal protective equipment and to seek advice before operating this equipment in a manner other than as described in this manual.



The soft starter is not user serviceable. The unit should only be serviced by authorised service personnel. **Unauthorised tampering with the unit will void the product warranty.**



### WARNING – FOR YOUR SAFETY

- The STOP function of the soft starter does not isolate dangerous voltages from the output of the starter. The soft starter must be disconnected by an approved electrical isolation device before accessing electrical connections.
- Soft starter protection features apply to motor protection only. It is the user's responsibility to ensure safety of personnel operating machinery.
- The soft starter is a component designed for integration within an electrical system; it is therefore the responsibility of the system designer/user to ensure the system is safe and designed to comply with relevant local safety standards.

## 2 Caution statements

### 2.1 Electrical shock risk

#### 2.1 Electrical shock risk



##### **WARNING – ELECTRICAL SHOCK HAZARD**

The voltages present in the following locations can cause severe electric shock and may be lethal:

- AC supply cables and connections
- Output cables and connections
- Many internal parts of the starter



##### **CAUTION – SHORT CIRCUIT**

The soft starter is not short circuit proof. After severe overload or short circuit, the operation of the soft starter should be fully tested by an authorised service agent.



##### **CAUTION – GROUNDING AND BRANCH CIRCUIT PROTECTION**

It is the responsibility of the user or person installing the soft starter to provide proper grounding and branch circuit protection according to local electrical safety codes.

## 2.2 Unexpected operation



### **WARNING – ACCIDENTAL STARTS**

In some installations, accidental starts may pose an increased risk to safety of personnel or damage to the machines being driven. In such cases, it is recommended that the power supply to the soft starter is fitted with an isolating switch and a circuit-breaking device (eg power contactor) controllable through an external safety system (eg emergency stop, fault detector).



### **WARNING – STARTER MAY START OR STOP UNEXPECTEDLY**

The soft starter will respond to control commands from various sources, and could start or stop unexpectedly. Always disconnect the soft starter from three-phase motor supply voltage before accessing the starter or load.



### **WARNING – DISCONNECT MAINS BEFORE ACCESSING STARTER OR LOAD**

The soft starter has built-in protections that can put the starter into fault state and thus stop the motor. Voltage fluctuations, power cuts and motor jams may also cause fault conditions.

The motor could restart after the causes of shutdown are rectified, which may be dangerous for personnel. Always disconnect the soft starter from three-phase motor supply voltage before accessing the starter or load.



### **CAUTION – MECHANICAL DAMAGE FROM UNEXPECTED RESTART**

The motor could restart after the causes of shutdown are rectified, which may be dangerous for certain machines or installations. In such cases, it is essential that appropriate arrangements are made against restarting after unscheduled stops of the motor.

## 2 Caution statements

### 2.3 Motor overload memory



#### **CAUTION – FIRST TIME APPLYING CONTROL POWER**

Some models use magnetic latching bypass contactors. It is possible for these to get knocked onto the ON position during transportation.

The starter will automatically reset these to the OFF position shortly after control power is applied. However, to prevent the possibility of either motor damage or an accidental start, it is recommended that on a new starter, control power is applied before connecting the three-phase motor supply.

### 2.3 Motor overload memory

The S711 has no battery backup or real-time clock, and consequently is unable to calculate elapsed off time. Because of this, it does not support a thermal memory function while control power is off. The motor overload will be reset to zero if control power is cycled.

### 2.4 FCC Class A device

This equipment has been tested and found to comply with the limits for a Class A digital device, pursuant to part 15 of the FCC rules. These limits are designed to provide reasonable protection against harmful interference when the equipment is operated in a commercial environment. This equipment generates, uses, and can radiate radio frequency and, if not installed and used in accordance with the instruction manual, may cause harmful interference to radio communications. Operation of this equipment in a residential area is likely to cause harmful interference, in which case the user will be required to correct the interference at his own expense.

## 2.5 Avertissements à l'attention des clients canadiens



### AVERTISSEMENT

L'icône AVERTISSEMENT ci-contre signale les informations concernant des risques pouvant entraîner des blessures graves, voire mortelles. Pour votre sécurité, veuillez consulter les avertissements sur cette page ou demander une copie du présent manuel en français auprès de votre distributeur local.



### AVERTISSEMENT – RISQUE DE CHOC ÉLECTRIQUE

Les zones suivantes sont soumises à des tensions pouvant provoquer des risques de chocs électriques graves, voire mortels :

- Raccordement et câbles d'alimentation AC
- Câbles et raccordements de sortie
- De nombreuses pièces internes du démarreur



### AVERTISSEMENT – PAR SÉCURITÉ

- La fonction STOP du démarreur progressif n'isole pas des tensions dangereuses de la sortie du démarreur. Le démarreur progressif doit être déconnecté par un dispositif d'isolement électrique approprié avant d'accéder aux connexions électriques.
- Les fonctions de protection du démarreur progressif ne concernent que la protection du moteur. Il relève de la responsabilité de l'utilisateur d'assurer la sécurité des personnes travaillant sur les machines.
- Le démarreur progressif est un appareil conçu pour s'intégrer dans un système électrique ; il relève donc de la responsabilité du concepteur ou de l'utilisateur de veiller à ce que ce système soit sûr et conçu selon les normes de sécurité locales en vigueur.

## 2 Caution statements

### 2.5 Avertissements à l'attention des clients canadiens



#### **AVERTISSEMENT – DÉMARRAGES ACCIDENTELS**

Dans certaines installations, des démarrages accidentels peuvent provoquer un risque supplémentaire pour la sécurité des personnes ou endommager les machines contrôlées. Dans de tels cas, il est recommandé de doter l'alimentation du démarreur progressif d'un interrupteur d'isolement et d'un coupe-circuit (par exemple, un disjoncteur) contrôlable à partir d'un système de sécurité externe (par exemple, un arrêt d'urgence, un détecteur de défaut).



#### **AVERTISSEMENT – LE DÉMARREUR PEUT DÉMARRER OU S'ARRÊTER À TOUT MOMENT**

Le démarreur progressif répond aux commandes de contrôle de différentes origines et peut par conséquent démarrer ou s'arrêter à tout moment. Toujours déconnecter le démarreur de la tension secteur avant d'accéder au démarreur ou à la charge.



#### **AVERTISSEMENT – DÉCONNECTER L'ALIMENTATION PRINCIPALE AVANT D'ACCÉDER AU DÉMARREUR OU À LA CHARGE**

Le démarreur progressif comporte des protections intégrées qui peuvent mettre le démarreur en état de défaut et ainsi arrêter le moteur. Les fluctuations de tension, les coupures de courant et les blocages de moteur peuvent également provoquer des conditions de panne.

Le moteur pourrait redémarrer une fois que les causes de l'arrêt ont été résolues, ce qui pourrait mettre en danger le personnel. Toujours déconnecter le démarreur de la tension secteur avant d'accéder au démarreur ou à la charge.



#### **AVERTISSEMENT**

Ne pas appliquer la tension du secteur au démarreur tant que tout le câblage n'est pas terminé.



#### **AVERTISSEMENT**

Toujours appliquer la tension de commande avant (ou en même temps que) la tension secteur.

2.5 Avertissements à l'attention des clients canadiens



**AVERTISSEMENT**

Lors du raccordement du soft starter en connexion 6 fils, toujours installer un contacteur principal ou un disjoncteur magnéto-thermique à bobine de déclenchement.



**AVERTISSEMENT**

Si l'entrée de démarrage est fermée lorsque la tension de commande est appliquée, le démarreur tentera d'effectuer un démarrage.

Vérifier que l'entrée de démarrage/arrêt est ouverte avant d'appliquer la tension de commande.

## 3 System design

### 3.1 Feature list

## 3 System design

### 3.1 Feature list

#### **Streamlined setup process**

- Configuration profiles for common applications
- Built-in metering and display of inputs/outputs status

#### **Easy to understand interface**

- Multi-language menus and displays
- Descriptive parameter names and feedback messages
- Real-time performance graphs

#### **Supports energy efficiency**

- IE3 and IE4 compatible
- 99% energy efficient when running
- Soft start technology avoids harmonic distortion

#### **Extensive range of models**

- 12~560 A (nominal)
- 200~575 V AC
- Internal bypass
- In-line or inside delta connection

#### **Extensive input and output options**

- Digital inputs  
(2 x fixed function,  
2 x programmable)
- Relay outputs  
(1 x fixed function,  
2 x programmable)

#### **Versatile starting and stopping options**

- Pump control
- Constant current
- Current ramp
- Timed voltage ramp soft stop
- Coast to stop
- DC brake
- Soft brake
- Reverse direction

#### **Customisable protection**

- Motor overload
- Excess start time
- Undercurrent/Overcurrent
- Underpower/Overpower
- Undervoltage/Overvoltage
- Current imbalance
- External fault inputs
- Motor thermistor
- Restart delay
- Phase sequence
- Frequency

#### **Cybersecurity**

- PIN number protection
- Digitally signed firmware
- Secure Bluetooth pairing
- Secure boot implementation

#### **Network communication**

- On-board Modbus RTU
- Optional: EtherNet/IP, Modbus TCP, Profinet

## 3.2 Model code

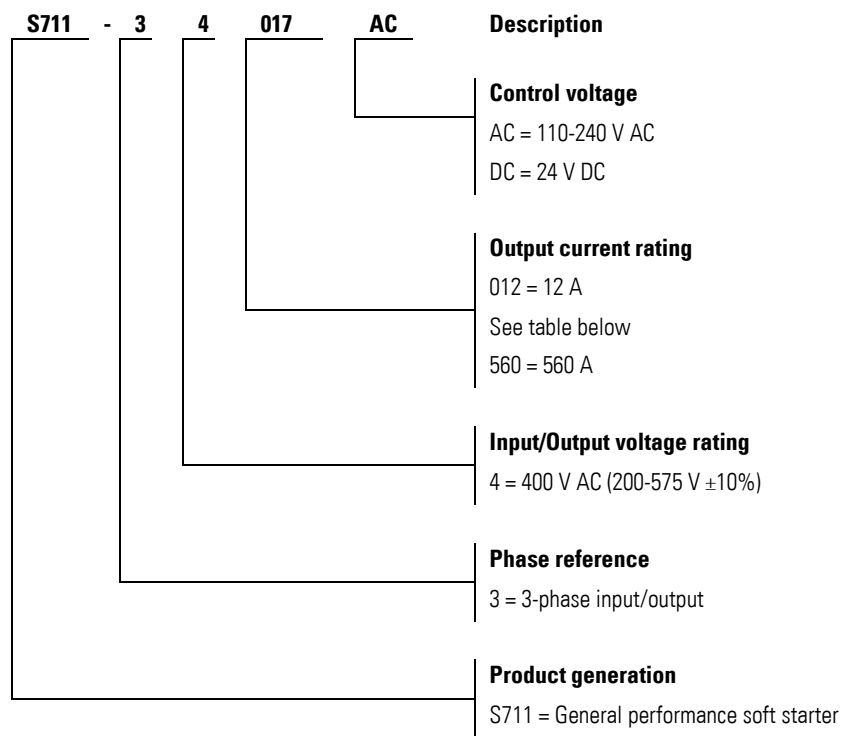

Table 3: Output current rating

Frame Size 1	Frame Size 2	Frame Size 3	Frame Size 4
012 = 12 A, 5.5 kW, 7.5 HP	062 = 62 A, 30 kW, 40 HP	140 = 140 A, 75 kW, 100 HP	320 = 320 A, 185 kW, 250 HP
017 = 17 A, 7.5 kW, 10 HP	075 = 75 A, 37 kW, 50 HP	170 = 170 A, 90 kW, 125 HP	410 = 410 A, 220 kW, 300 HP
025 = 25 A, 11 kW, 15 HP	088 = 88 A, 45 kW, 60 HP	210 = 210 A, 110 kW, 150 HP	480 = 480 A, 250 kW, 350 HP
032 = 32 A, 15 kW, 20 HP	115 = 115 A, 55 kW, 75 HP	250 = 250 A, 132 kW, 200 HP	560 = 560 A, 315 kW, 450 HP
047 = 47 A, 22 kW, 30 HP			

**A** rating at 40 °C

**kW** rating at 400 V AC, 50 Hz, 40 °C

**HP** rating at 460 V AC, 60 Hz, 50 °C

## 3 System design

### 3.3 Model selection

## 3.3 Model selection

### 3.3.1 Starter sizing

The soft starter must be the correct size for the motor and the application.

Select a soft starter that has a current rating at least equal to the motor's full load amperage (nameplate) rating, at the start duty.

The soft starter's current rating determines the maximum motor size it can be used with. The rating depends on the number of starts per hour, the length and current level of the start, and the amount of time the soft starter will be off (not passing current) between starts. Maximum altitude and ambient temperature can also affect the rating, and these are noted for each set of ratings.

The soft starter's current rating is only valid when used in the conditions specified in the AC-53/AC-3 utilisation code. The current rating may be higher or lower in different operating conditions.

### 3.3.2 AC-53b/AC-3b format (bypassed current rating)

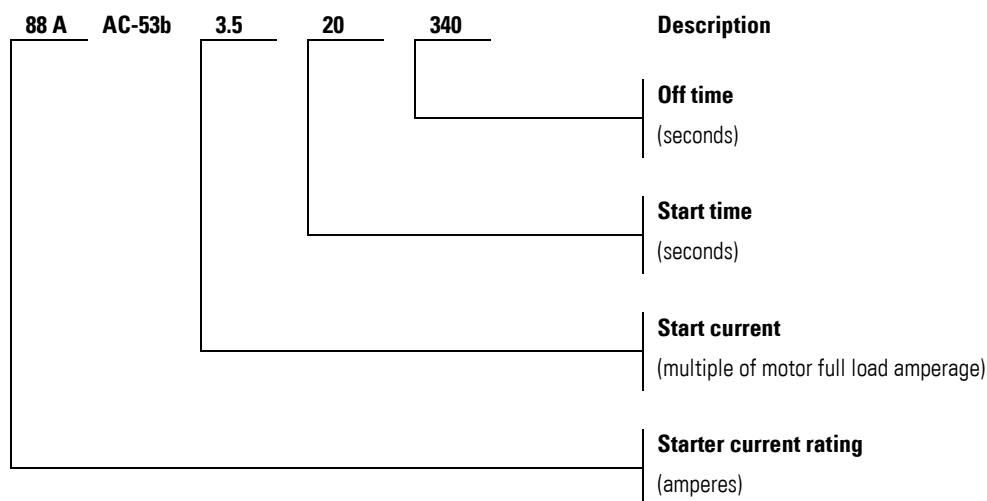

Figure 1: AC-53b/AC-3b format (bypassed current rating)

### 3.4 Current ratings

Contact your local supplier for ratings under operating conditions not covered by these ratings charts.

#### 3.4.1 IEC ratings

All ratings are calculated at altitude of up to 1000 metres and ambient temperature of 40 °C.

##### 3.4.1.1 In-line installation, bypassed

Table 4: In-line installation, bypassed (IEC)

	<b>3.5-20:340</b>	<b>3.5-30:330</b>	<b>4.0-10:350</b>	<b>4.0-20:340</b>	<b>5.0-5:355</b>
S711-34012...	12	11	11	10	10
S711-34017...	17	16	16	15	14
S711-34025...	25	22	25	22	23
S711-34032...	32	29	32	28	29
S711-34047...	47	42	47	41	47
S711-34062...	62	59	60	54	52
S711-34075...	75	69	74	66	67
S711-34088...	88	81	87	77	78
S711-34115...	115	107	114	101	102
	<b>3.5-20:580</b>	<b>3.5-30:570</b>	<b>4.0-10:590</b>	<b>4.0-20:580</b>	<b>5.0-5:595</b>
S711-34140...	140	130	138	122	122
S711-34170...	170	159	167	149	147
S711-34210...	210	193	208	184	182
S711-34250...	250	231	246	219	215
S711-34320...	320	298	319	280	295
S711-34410...	410	373	410	359	402
S711-34480...	480	438	480	420	467
S711-34560...	560	501	560	490	560

### 3 System design

#### 3.4 Current ratings

##### 3.4.1.2 Inside delta installation, bypassed

Table 5: Inside delta installation, bypassed (IEC)

	<b>3.5-20:340</b>	<b>3.5-30:330</b>	<b>4.0-10:350</b>	<b>4.0-20:340</b>	<b>5.0-5:355</b>
S711-34012...	18	16.5	16.5	15	15
S711-34017...	25.5	24	24	22.5	21
S711-34025...	37.5	33	37.5	33	34.5
S711-34032...	48	43.5	48	42	43.5
S711-34047...	70.5	63	70.5	61.5	70.5
S711-34062...	93	88.5	90	81	78
S711-34075...	112.5	103.5	111	99	100.5
S711-34088...	132	121.5	130.5	115.5	117
S711-34115...	172.5	160.5	171	151.5	153
	<b>3.5-20:580</b>	<b>3.5-30:570</b>	<b>4.0-10:590</b>	<b>4.0-20:580</b>	<b>5.0-5:595</b>
S711-34140...	210	195	207	183	183
S711-34170...	255	238.5	250.5	223.5	220.5
S711-34210...	315	289.5	312	276	273
S711-34250...	375	346.5	369	328.5	322.5
S711-34320...	480	447	478.5	420	442.5
S711-34410...	615	559.5	615	538.5	603
S711-34480...	720	657	720	630	700.5
S711-34560...	840	751.5	840	735	840

### 3.4.2 NEMA motor ratings

All ratings are calculated at altitude of up to 1000 metres and ambient temperature of 50 °C.

#### 3.4.2.1 In-line installation, bypassed

Table 6: In-line installation, bypassed (NEMA)

	Normal 350%, 20 s, 6 starts per hour				Heavy 450%, 30 s, 6 starts per hour			
	A	HP @200 V AC	HP @220 V AC	HP @460 V AC	A	HP @200 V AC	HP @220 V AC	HP @460 V AC
S711-34012...	10	3	3	7.5	7	2	2	5
S711-34017...	15	5	5	10	11	3	3	7.5
S711-34025...	22	7.5	7.5	15	15	5	5	10
S711-34032...	29	10	10	20	21	7.5	7.5	15
S711-34047...	43	15	15	30	29	10	10	20
S711-34062...	56	20	20	40	41	10	10	30
S711-34075...	67	20	25	50	49	15	15	40
S711-34088...	82	25	30	60	59	20	20	40
S711-34115...	107	30	40	75	77	25	25	60
S711-34140...	121	40	50	100	88	30	30	60
S711-34170...	153	50	60	125	111	40	40	75
S711-34210...	191	60	75	150	136	50	50	100
S711-34250...	232	75	100	200	167	60	60	125
S711-34320...	288	100	100	250	208	75	75	150
S711-34410...	371	125	150	300	262	100	100	200
S711-34480...	444	150	150	350	315	100	125	250
S711-34560...	518	200	200	450	360	125	150	300

### 3 System design

#### 3.4 Current ratings

##### 3.4.2.2 Inside delta installation, bypassed

Table 7: Inside delta installation, bypassed (NEMA)

	Normal 350%, 20 s, 6 starts per hour				Heavy 450%, 30 s, 6 starts per hour			
	A	HP @200 V AC	HP @220 V AC	HP @460 V AC	A	HP @200 V AC	HP @220 V AC	HP @460 V AC
S711-34012...	15	5	5	10	10.5	3	3	7.5
S711-34017...	22.5	7.5	7.5	15	16.5	5	5	10
S711-34025...	33	10	10	25	22.5	7.5	7.5	15
S711-34032...	43.5	15	15	30	31.5	10	10	20
S711-34047...	64.5	20	25	50	43.5	15	15	30
S711-34062...	84	25	30	60	61.5	20	20	40
S711-34075...	94.5	30	30	75	73.5	25	25	50
S711-34088...	114	40	40	100	88.5	30	30	60
S711-34115...	160.5	50	60	125	115.5	40	40	75
S711-34140...	181.5	60	60	150	132	50	50	100
S711-34170...	229.5	75	75	150	166.5	60	60	125
S711-34210...	286.5	100	100	200	204	75	75	150
S711-34250...	348	125	125	250	250.5	75	100	200
S711-34320...	432	150	150	350	312	100	125	250
S711-34410...	556.5	200	200	450	393	125	150	300
S711-34480...	666	250	250	500	472.5	150	200	400
S711-34560...	777	300	300	600	540	200	200	450

### 3.5 Dimensions and weights

→ The drawings in this section are not to scale and are for illustrative purposes only.

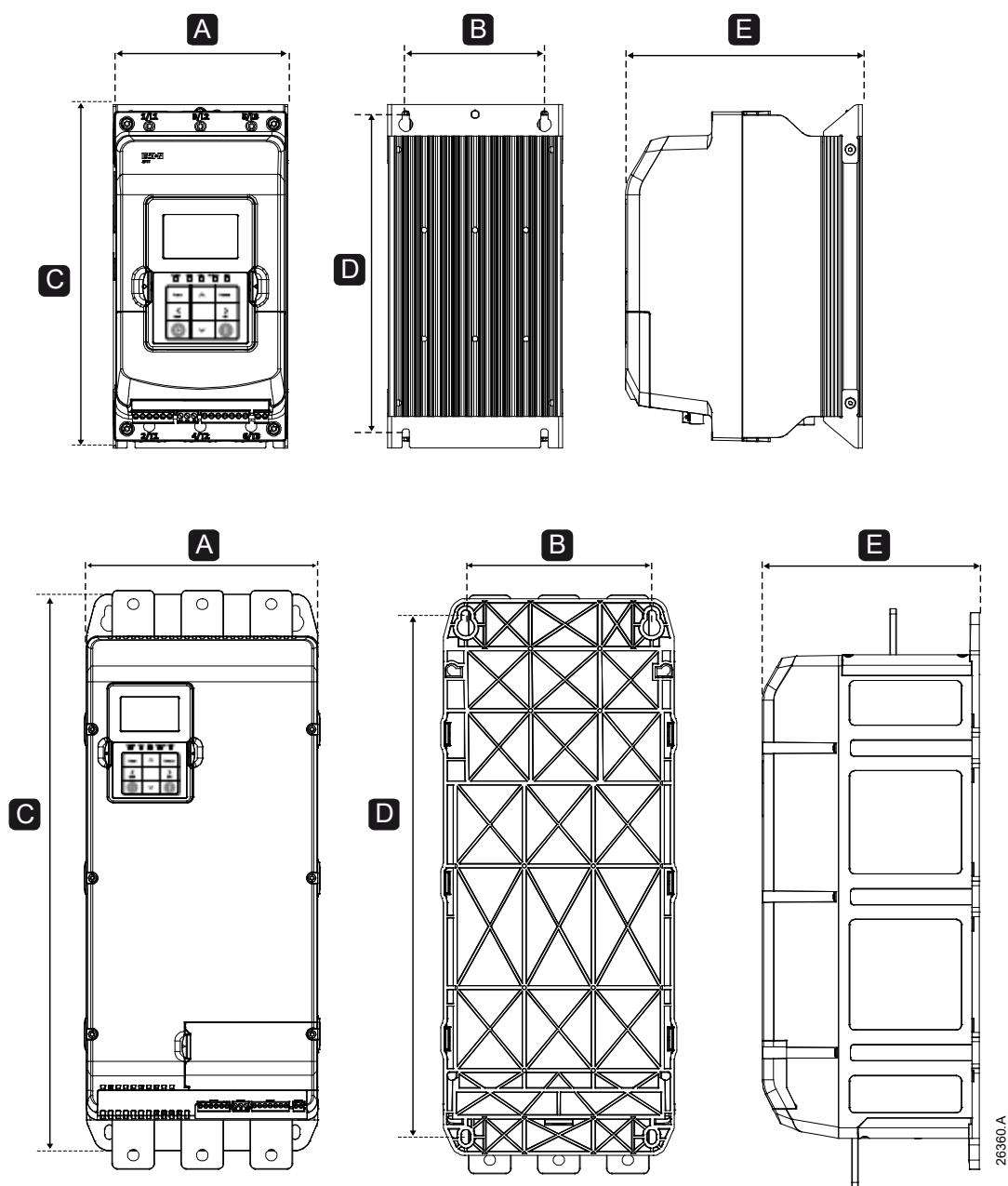

Figure 2: Dimensions and weights

### 3 System design

#### 3.5 Dimensions and weights

Table 8: Dimensions and weights

		Width mm (inch)		Width mm (inch)		Depth mm (inch)	Weight kg (lb)
		A	B	C	D	E	F
Frame size 1	S711-34012...						
	S711-34017...						
	S711-34025...	128	102	252	234	174.5	3.6
	S711-34032...	(5.04)	(4.02)	(9.93)	(9.22)	(6.88)	(7.94)
	S711-34047...						
Frame size 2	S711-34062...						
	S711-34075...	128	102	281.3	263	190.2	5.1
	S711-34088...	(5.04)	(4.02)	(11.08)	(10.36)	(7.49)	(11.25)
Frame size 3	S711-34115...						
	S711-34140...						
	S711-34170...	202.6	168	385.3	342.7	218.4	11.8
	S711-34210...	(7.98)	(6.62)	(15.18)	(13.50)	(8.60)	(26.02)
Frame size 4	S711-34250...						
	S711-34320...						
	S711-34410...	222	175	545	492	204.5	20.1
	S711-34480...	(8.75)	(6.90)	(21.47)	(19.38)	(8.06)	(44.32)
	S711-34560...						

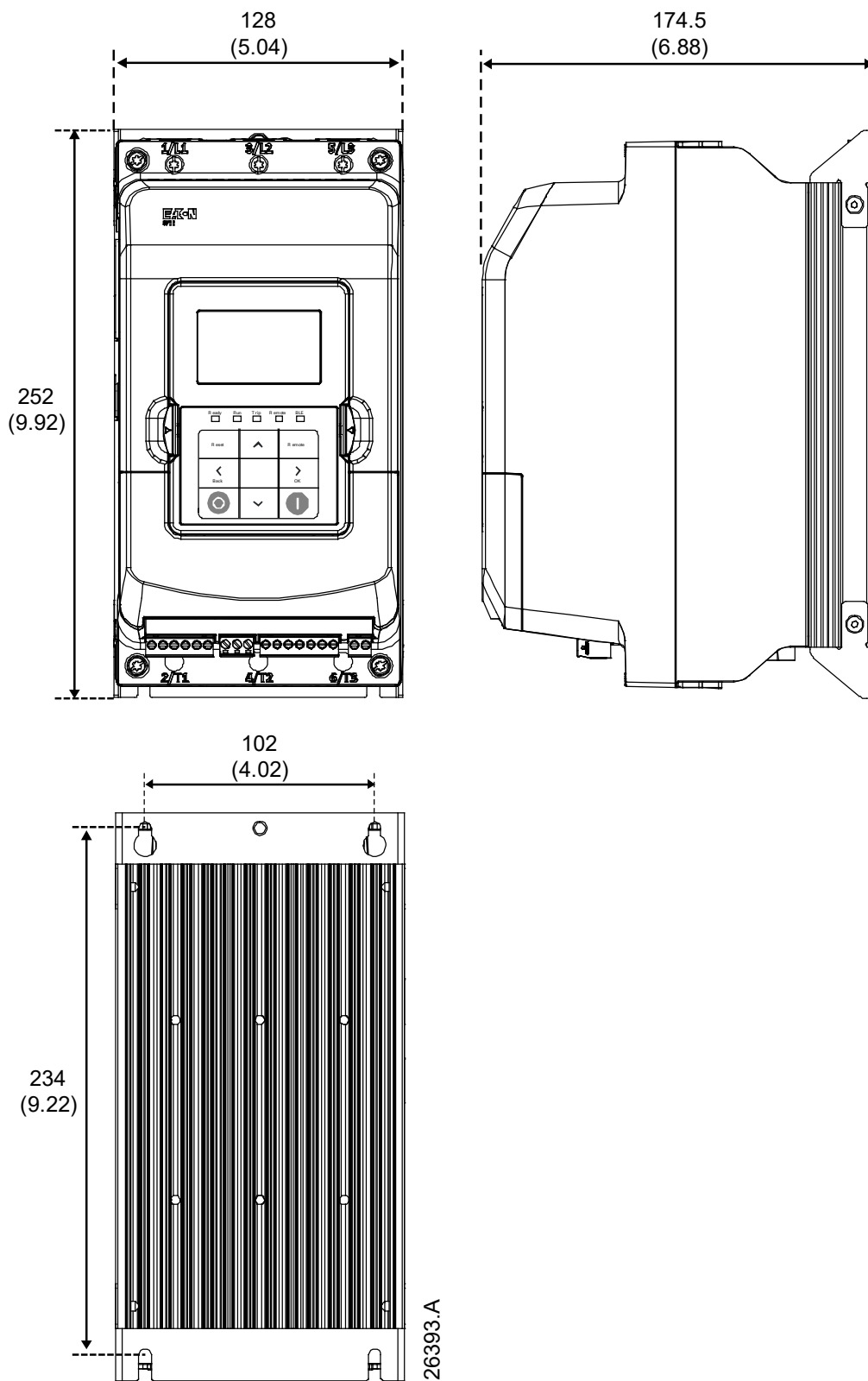

Figure 3: S711-34012...~ S711-34047... dimensions

### 3 System design

#### 3.5 Dimensions and weights

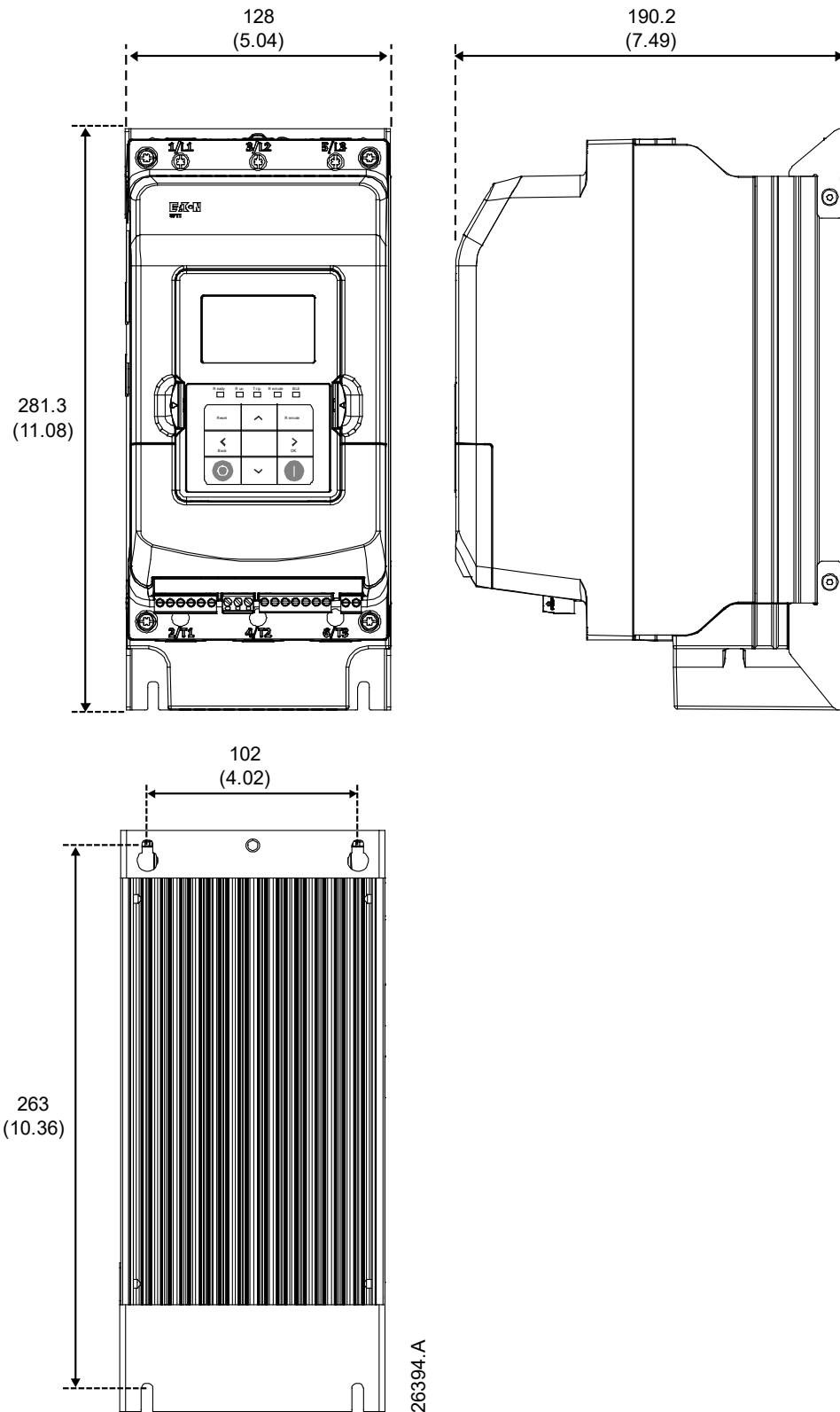

Figure 4: S711-34062...~ S711-34115... dimensions

3.5 Dimensions and weights

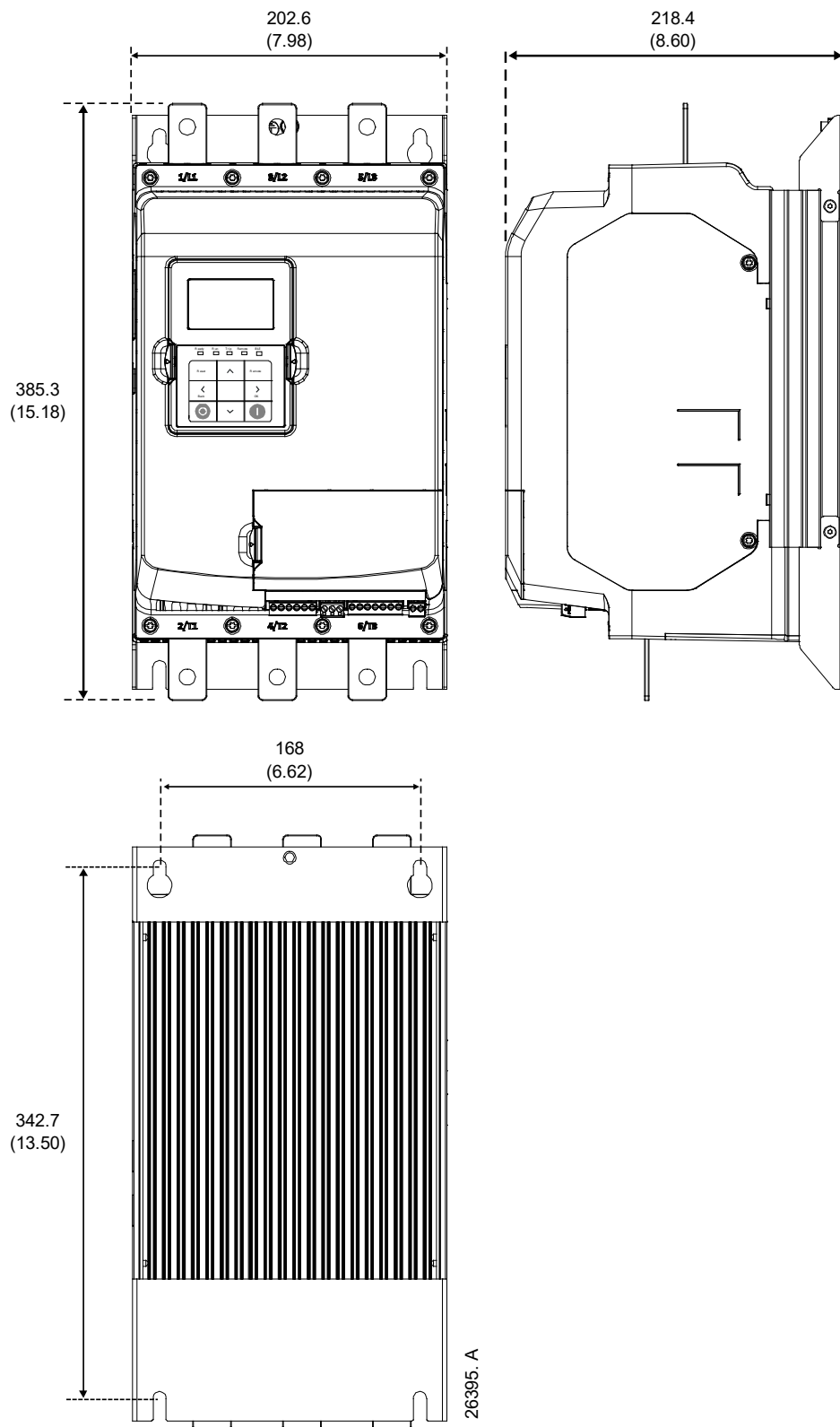

Figure 5: S711-34140...~ S711-34250... dimensions

### 3 System design

#### 3.5 Dimensions and weights

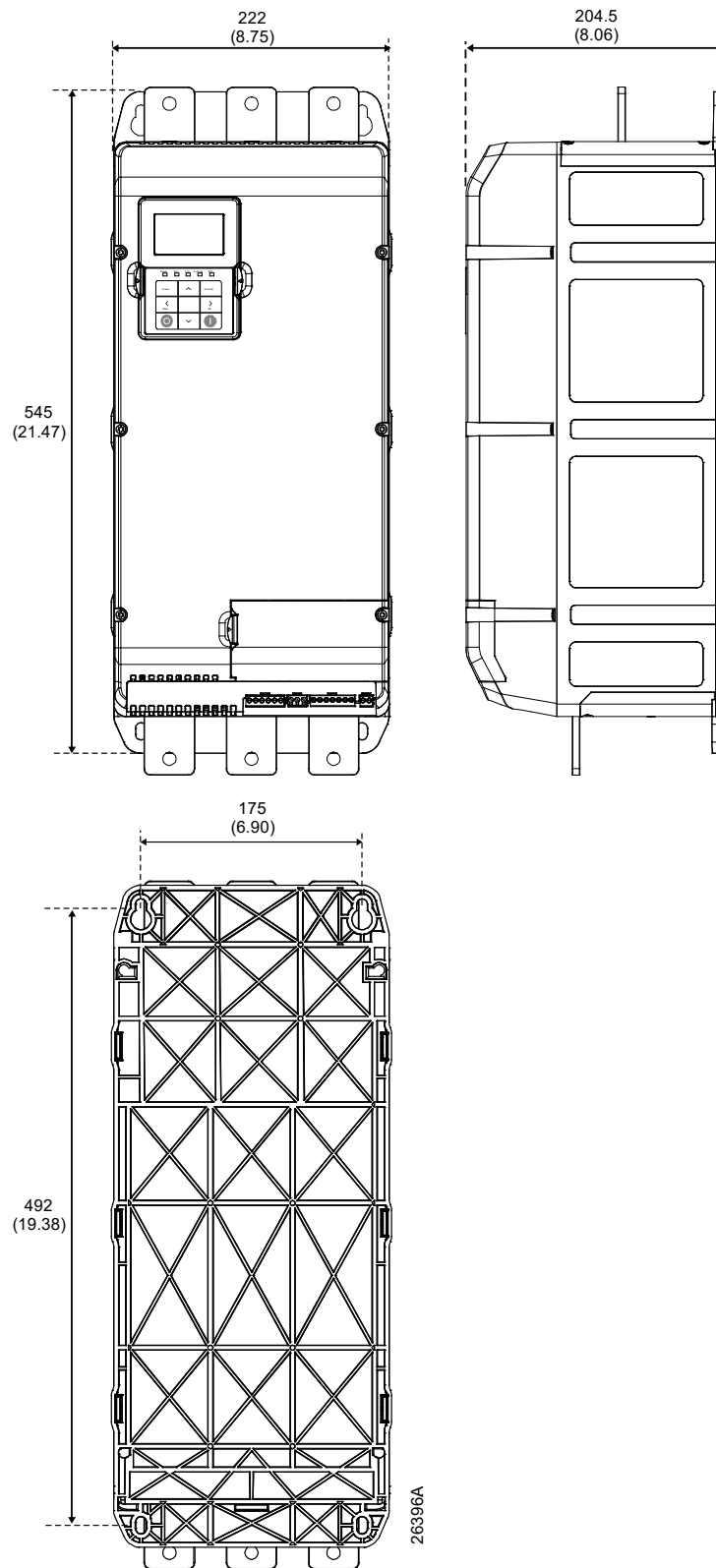

Figure 6: S711-34320...~ S711-34560... dimensions

### 3.6 Physical installation

➔ The soft starter can be mounted up to 15° from vertical.

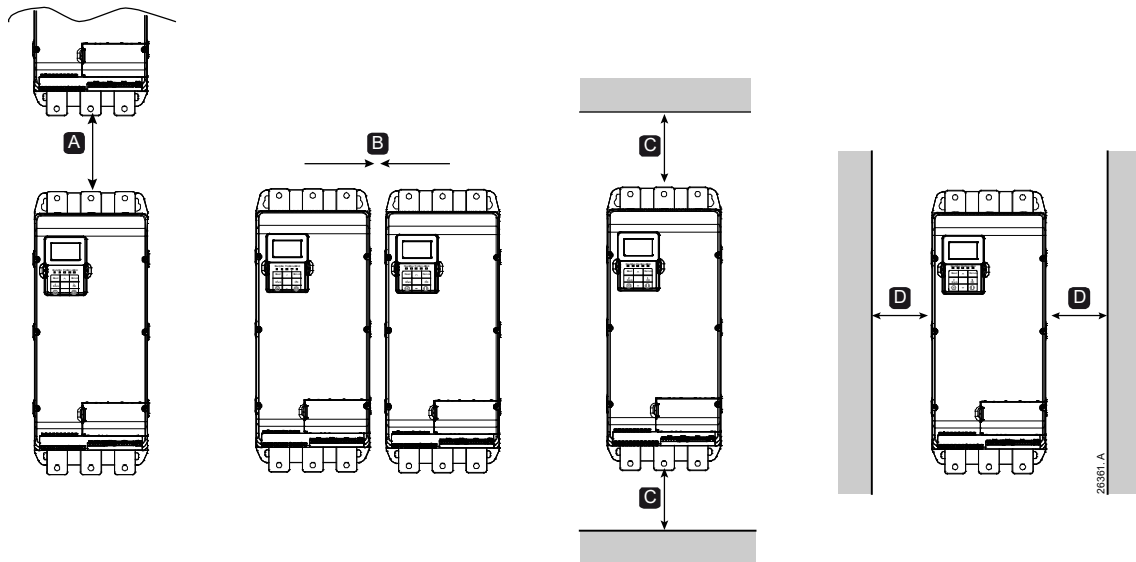

Figure 7: Minimum clearances

Table 9: Mounting clearances

		Between starters mm (inch)		Solid surfaces mm (inch)	
		A	B	C	D
Frame size 1	S711-34012...				
	S711-34017...				
	S711-34025...	125	10	75	25
	S711-34032...	(4.93)	(0.39)	(2.96)	(0.99)
Frame size 2	S711-34047...				
	S711-34062...				
	S711-34075...	125	10	75	25
Frame size 3	S711-34088...	(4.93)	(0.39)	(2.96)	(0.99)
	S711-34115...				
	S711-34140...				
	S711-34170...	125	25	125	25
Frame size 4	S711-34210...	(4.93)	(0.99)	(4.93)	(0.99)
	S711-34250...				
	S711-34320...				
	S711-34410...	125	25	125	25
	S711-34480...	(4.93)	(0.99)	(4.93)	(0.99)
	S711-34560...				

## 3 System design

### 3.7 Accessories

## 3.7 Accessories

### 3.7.1 Communication cards

The soft starter includes on-board Modbus RTU for network communication. Easy-to-install communication cards are available for other protocols.

Available protocols:

EtherNet/IP, Modbus TCP, Profinet.

### 3.7.2 Keypad

For the device to function, the keypad must be connected to the starter.

The keypad on the starter can be detached. You can use it directly on the starter or unclip it and mount it remotely, connecting it to the starter with a patch cable (up to 3 metres away from the starter). For instance, you can mount it on the front of the panel.

Replacement keypads are available as an accessory.

### 3.7.3 Finger protection kit

Finger protection may be specified for personnel safety. Finger protection kits fit over the soft starter terminals to prevent accidental contact with live terminals from the front and sides.

Finger protection kits are available for models S711-34140...~S711-34560..., which have exposed busbar terminals.

Contact your local supplier for assistance selecting the correct finger protection kit.

### 3.7.4 S711 Connect app

With the S711 Connect app you can manage parameters, view and download event logs, and update firmware. See the S711 Connect App Instructions for more details.

### 3.8 Main contactor or circuit breaker

A main contactor or circuit breaker should be installed with the soft starter.

- A main contactor is recommended to protect the soft starter from voltage disturbances on the network, while stopped. Select a contactor with an AC-3 rating greater than or equal to the FLA rating of the connected motor.
- Use a shunt trip circuit breaker to isolate the motor circuit in the event of a fault in the soft starter. The shunt trip mechanism must be powered from the supply side of the circuit breaker or from a separate control supply.
- Use the main contactor output [13, 14] to control the main contactor.



#### WARNING

When connecting the soft starter in inside delta configuration, always install a main contactor or shunt trip circuit breaker.

### 3.9 Power factor correction

If power factor correction is used, a dedicated contactor should be used to switch in the capacitors.

To use the soft starter to control power factor correction, connect the PFC contactor to a programmable relay set to 'Bypassed'. When the motor reaches full speed, the relay will close and power factor correction will be switched in. Do not use the soft starter relay output to directly switch in power factor correction.

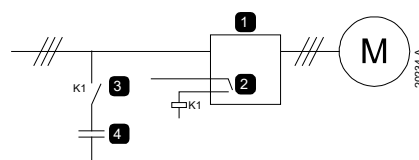

- 1 Soft starter
- 2 Programmable output (set = Bypassed)
- 3 Power factor correction contactor
- 4 Power factor correction

Figure 8: Power factor correction



#### CAUTION

Power factor correction capacitors must be connected to the input side of the soft starter. Connecting power factor correction capacitors to the output side will damage the soft starter.

## 3 System design

### 3.10 Short circuit protection devices (SCPD)

#### 3.10 Short circuit protection devices (SCPD)

Fuses and MCCBs may be installed to protect the soft starter or the installation.

#### 3.11 IEC coordination with short circuit protection devices

##### 3.11.1 Type 1 coordination

Type 1 coordination requires that, in the event of a short circuit on the output side of a soft starter, the fault must be cleared without risk of injury to personnel. There is no requirement that the soft starter must remain operational after the fault.

HRC fuses (such as Bussmann fuses) can be used for Type 1 coordination according to the IEC 60947-4-2 standard.

##### 3.11.2 Type 2 coordination

Type 2 coordination requires that in the event of a short circuit on the output side of a soft starter, the fault must be cleared without risk of injury to personnel or damage to the soft starter.

Semiconductor fuses for Type 2 circuit protection are additional to HRC fuses or MCCBs that form part of the motor branch circuit protection.



#### CAUTION

DC Brake: A high brake torque setting can result in peak currents up to motor DOL being drawn while the motor is stopping. Ensure protection fuses installed in the motor branch circuit are selected appropriately.



#### CAUTION

Integral solid state short circuit protection does not provide branch circuit protection. Branch circuit protection must be provided in accordance with the National Electrical Code and any additional local codes.

## 3.11 IEC coordination with short circuit protection devices

## 3.11.3 IEC coordination with short circuit protection devices

These fuses and MCCBs were selected based on start current of 3.5 x FLA for 20 seconds.

Table 10: IEC coordination with short circuit protection devices

Model	Nominal rating (A) 350%, 20 s	SCR I <sub>t</sub> (A <sup>2</sup> s)	Type 1 coordination		Type 2 coordination
			Fuse 525 V AC, 100 kA	MCCB 500 V AC, 100 kA	Fuse 600 V AC, 100 kA
S711-34012...	12	1.15	25NHG000B	NZMH2-A25-BT	170M3008
S711-34017...	17	1.15	32NHG000B	NZMH2-A32-BT	170M3008
S711-34025...	25	6.60	40NHG000B	NZMH2-A50-BT	170M3009
S711-34032...	32	8.00	50NHG000B	NZMH2-A63-BT	170M3010
S711-34047...	47	15.00	80NHG000B	NZMH2-A100-BT	170M3011
S711-34062...	62	15.00	100NHG00B	NZMH2-A125-BT	170M3012
S711-34075...	75	25.00	100NHG00B	NZMH2-A160-BT	170M3013
S711-34088...	88	65.00	125NHG00B	NZMH2-A160-BT	170M3014
S711-34115...	115	101.00	160NHG00B	NZMH2-A200-BT	170M3016
S711-34140...	140	231.00	200NHG2B	NZMH2-A250-BT	170M3018
S711-34170...	170		224NHG2B	NZMH2-A250-BT	170M5008
S711-34210...	210	320.00	250NHG2B	NZMH2-A320-BT	170M5009
S711-34250...	250		315NHG2B	NZMH3-A320-BT	170M6008
S711-34320...	320		400NHG3B	NZMH3-A400-BT	170M6008
S711-34410...	410	605.00	425NHG3B	NZMH3-A500-BT	170M6010
S711-34480...	480	781.00	500NHG3B	NZMH3-AX630	170M6011
S711-34560...	560	1200.00	630NHG4B-690	NZMH4-AX1000	170M6012

### 3 System design

#### 3.12 UL coordination with short circuit protection devices

#### 3.12 UL coordination with short circuit protection devices

Models marked as UL approved were tested with short circuit and overcurrent protection devices listed in the tables below.

##### 3.12.1 Standard fault short circuit

Suitable for use on a circuit capable of delivering up to the stated fault current, 600 V AC maximum, when protected by any UL listed fuses or circuit breakers sized according to the NEC.

Table 11: Standard fault short circuit

Model	Nominal rating (A) 350%, 20 s	3-cycle short cct rating @600 V AC
S711-34012...	12	5 kA
S711-34017...	17	
S711-34025...	25	
S711-34032...	32	
S711-34047...	47	
S711-34062...	62	
S711-34075...	75	10 kA
S711-34088...	88	
S711-34115...	115	
S711-34140...	140	
S711-34170...	170	
S711-34210...	210	18 kA
S711-34250...	250	
S711-34320...	320	
S711-34410...	410	
S711-34480...	480	
S711-34560...	560	30 kA

## 3.12 UL coordination with short circuit protection devices

## 3.12.2 High fault short circuit

Suitable for use on a circuit capable of delivering up to the stated fault current, when protected by the specified circuit breaker or by fuses of the stated class and rating.

These protection devices were selected based on start current of 3.5 x FLA for 20 seconds.

Table 12: High fault short circuit

Model	Nominal rating (A) 350%, 20 s	SCR I <sub>t</sub> (A <sup>2</sup> s)	MCCB 480 V AC, 65 kA		Fuse 600 V AC, 100 kA
			PDG	NZM	
S711-34012...	12	1.15	PDG23M0030TFFJ	NZMH2-A32-BT-NA	
S711-34017...	17	1.15	PDG23M0040TFFJ	NZMH2-A40-BT-NA	
S711-34025...	25	6.60	PDG23M0060TFFJ	NZMH2-A63-BT-NA	
S711-34032...	32	8.00	PDG23M0080TFFJ	NZMH2-A80-BT-NA	
S711-34047...	47	15.00	PDG23M0150TFFJ	NZMH2-A125-BT-NA	
S711-34062...	62	15.00	PDG23M0175TFFJ	NZMH2-A160-BT-NA	
S711-34075...	75	25.00	PDG23M0175TFFJ	NZMH2-A200-BT-NA	
S711-34088...	88	65.00	PDG23M0225TFFJ	NZMH2-A250-BT-NA	
S711-34115...	115	101.00	PDG33P0225TFFL	NZMH2-A250-BT-NA	
S711-34140...	140	231.00	PDG33M0350TFAJ	NZMH3-AX400-NA	
S711-34170...	170		PDG33M0400TFAJ	NZMH3-AX400-NA	
S711-34210...	210	320.00	PDG33M0500TFAJ	NZMH3-AX600-NA	
S711-34250...	250		PDG33M0600TFAJ		
S711-34320...	320		PDG43M0800TFAJ		
S711-34410...	410	605.00	PDG43M0800TFAJ		
S711-34480...	480	781.00	PDG53M1200E2NW		
S711-34560...	560	1200.00			

## 3 System design

### 3.13 Specifications

#### 3.13 Specifications

##### 3.13.1 Supply

Three-phase motor voltage (L1, L2, L3)	
S711-34...	200~575 V AC (+10% -15%)
Control voltage (AC: N, L; DC: -, +)	
S711-34...AC	110~240 V AC (+10%/-15%), 600 mA
S711-34...DC	24 V DC ( $\pm$ 20%), 2.8 A
Mains frequency	50~60 Hz ( $\pm$ 5 Hz)
Mains control supply and relay output	
Rated insulation voltage	300 V AC
Rated impulse withstand voltage	4 kV
Main circuit	
Rated insulation voltage	600 V AC
Rated impulse withstand voltage	6 kV
Form designation	Bypassed, semiconductor motor starter Form 1

##### 3.13.2 Short circuit capability

Coordination with MCCBs and HRC fuses	Type 1
Coordination with semiconductor fuses	Type 2

##### 3.13.3 Radio and electromagnetic capability

Radio General	EN 301 489-1
BLE	EN 301 489-17
BLE	EN 300 328
EMC Immunity	IEC 60947-4-2
EMC Emissions	IEC 60947-4-2 Class A

##### 3.13.4 Inputs

Digital Input rating	Active 24 V DC, $\leq$ 20 mA
Motor thermistor [Ti+, Ti-]	Triggers $>3.6$ k $\Omega$ , reset $<1.6$ k $\Omega$

##### 3.13.5 Outputs

Main contactor output	10 A @ 250 V AC resistive, 5A @ 250 V AC AC-15 pf 0.3
Main contactor [13, 14]	Normally open
Programmable output	3 A @ 250 V AC resistive
Relay output 2 [23, 24]	Normally open
Relay output 3 [33, 34]	Normally open
Rated insulation voltage	300 V AC
Rated impulse withstand voltage	4 kV

**3.13.6 Environmental**

Operating temperature .....	-25 °C~60 °C (above 40 °C with derating)
Storage temperature .....	-40 °C~70 °C (+70 °C < 24 hrs)
Operating altitude .....	0~4000 m (above 1000 m with derating)
Humidity .....	5%~95% Relative Humidity
Pollution degree .....	Pollution Degree 3
Vibration .....	IEC 60068-2-6 (Fc)
Shock .....	IEC 60068-2-27 (Ea)
Protection	
S711-34012...~S711-34115... .....	IP20
S711-34140...~S711-34560... .....	IP00
Keypad (when remote mounted) .....	IP65

**3.13.7 Heat dissipation**

During Start .....	4.5 watts per ampere
During Run	
S711-34012~ S711-34047 .....	≤ 35 watts approx
S711-34062~ S711-34115 .....	≤ 50 watts approx
S711-34140~ S711-34250 .....	≤ 120 watts approx
S711-34320~ S711-34560 .....	≤ 140 watts approx

**3.13.8 Motor overload protection**

The soft starter uses a standard overload curve for motor protection. Trip classes 5, 10, 15, 20, 30 are available.

**3.13.9 Operational life (internal bypass contacts)**

.....	100 000 operations
-------	--------------------

**3.13.10 Accuracy**

Primary parameters (current, voltage, frequency).....	±5%
Secondary parameters (power, energy, power factor).....	±10%

Accuracy is degraded while starting and stopping.

### 3 System design

#### 3.14 Certifications

#### 3.14 Certifications

Table 13: Certifications

Certifications	Details
Bluetooth LE module	FCC ID: 2AC7Z-ESP32WROVERE ISED ID: 21098-ESPWROVERE
CCC (Pending)	Low-voltage Switchgear & Control Gear Part 4-2 GB/T 14048.6
CE	Low Voltage Directive (LVD) 2014/35/EU Radio Equipment Directive (RED) 2014/53/EU Electromagnetic Compatibility Directive (EMC) 2014/30/EU Restriction of Hazardous Substances Directive (RoHS) 2011/65/EU
UKCA	Electrical Equipment Safety Regulations 2016 No.1101 Radio Equipment Regulations 2017 No.1206 Electromagnetic Compatibility Regulations 2016 No.1091 Restriction of Hazardous Substances Regulations 2012 No.3032
CMIM (Pending)	LAW 24-09
RCM	Electrical Equipment Safety System
C-UL	CSA C22.2 No. 60947-4-2
UL	UL 60947-4-2
REACH	Restriction of Chemicals No 1907/2006 Enforcement Regulations 2008 No. 2852
Hazardous Substances	
China (Pending)	GB/T 26572-2011, SJ/T 11364-2014
UAE (Pending)	Cabinet Order No. 10/217
KSA (Pending)	01-09-21-179
USA	Minamata Convention on Mercury Proposition-65 Toxic Substances Control Act (TSCA) Conflict Minerals (Section 1502)
WEEE	Waste Electrical & Electronic Equipment Directive 2012/19/EU Waste Electrical & Electronic Equipment Regulations 2013 No.3113

#### 3.15 Disposal instructions



Equipment containing electrical components may not be disposed of together with domestic waste.

It must be collected separately as electrical and electronic waste according to local and currently valid legislation.

## 4 Installation

**WARNING**

Do not apply three-phase motor supply voltage to the starter until all wiring is complete.

**WARNING**

Always apply control voltage before (or with) three-phase motor supply voltage.

### 4.1 Command source

The soft starter can be started and stopped via the keypad, digital inputs, on-board Modbus RTU or optional communication card. The command source can be set using parameter P1.4 Command Source.

The **REMOTE** button on the keypad provides shortcut access to parameter P1.4 Command Source.



The default for P1.4 Command Source is 'Keypad'.

**CAUTION**

Enabling on-board Modbus RTU or optional Fieldbus communication cards as a command source means that the starter operation will be controlled by an external network-connected device. This increases the overall security risk. To mitigate this increased risk, ensure that you are following the recommended cybersecurity practices in Cybersecurity on page 82.

**CAUTION**

Modbus RTU is enabled by default. We strongly recommend that you use Safety Instrumented Systems (SIS) along with this component.



You can change on-board Modbus RTU settings at the soft starter, and over the network.

## 4 Installation

### 4.2 Setup procedure

#### 4.2 Setup procedure



#### **WARNING – ELECTRICAL SHOCK HAZARD**

The voltages present in the following locations can cause severe electric shock and may be lethal:

- AC supply cables and connections
- Output cables and connections
- Many internal parts of the starter



When setting up a new unit, you must set the 'User Configuration' parameters (P1.1~P1.4) at the soft starter, before setting any other parameters.

See Programmable parameters on page 108 for details.

1. Mount the soft starter (see Physical installation on page 37 for details).
2. Connect control wiring (see Start/Stop on page 50 for details).
3. Apply control voltage to the starter (see Control voltage on page 55 for details).
4. Configure your application:
  - Use the S711 Connect app to configure the starter via BLE, or
  - Use the keypad to configure the starter via the menu:
    1. Press **>** to open the Main Menu.
    2. Scroll to 'Quick Setup' and press **>** to open the menu.
    3. Scroll through the list to find your application, then press **>** to begin the configuration process (see Quick setup on page 76 for details).
5. If your application is not listed in Quick Setup:
  1. Press **<** to return to the Main Menu.
  2. Use **▼** to scroll to 'User Parameters' and press **>**.
  3. Scroll to 'Motor Details' and press **>**. Press **>** to edit parameter P2.1 Motor FLA.
  4. Set P2.1 to match the motor's full load amperage (FLA).
  5. Press **>** to save the setting.
  6. Then set the following parameters:
    7. P3.1 Start Mode, P3.2 Start Ramp Time, P3.3 Initial Current, P3.4 Current Limit, P3.9 Stop Mode, P3.10 Stop Time.
    8. If suitable for your application, also set:
      - P3.5 Pump Start Profile, P3.11 Pump Stop Profile.
6. Close the menu by pressing **<** repeatedly.

### 4.2 Setup procedure

7. (Optional) Use the built-in output signal test to confirm that the soft starter and associated equipment have been installed correctly (see Output signal test on page 71).
8. Remove all electrical power from the soft starter.
9. Connect the motor cables to starter output terminals 2/T1, 4/T2, 6/T3.
10. Connect the three-phase motor supply cables to starter input terminals 1/L1, 3/L2, 5/L3 (see Power terminations on page 57).

The soft starter is now ready to control the motor.

## 4 Installation

### 4.3 Inputs

#### 4.3 Inputs



#### CAUTION

The digital inputs are powered by the soft starter. Do not apply external voltage to the digital input terminals.



Cables to the digital inputs must be segregated from the three-phase motor supply and motor cabling.

#### 4.3.1 Input terminals

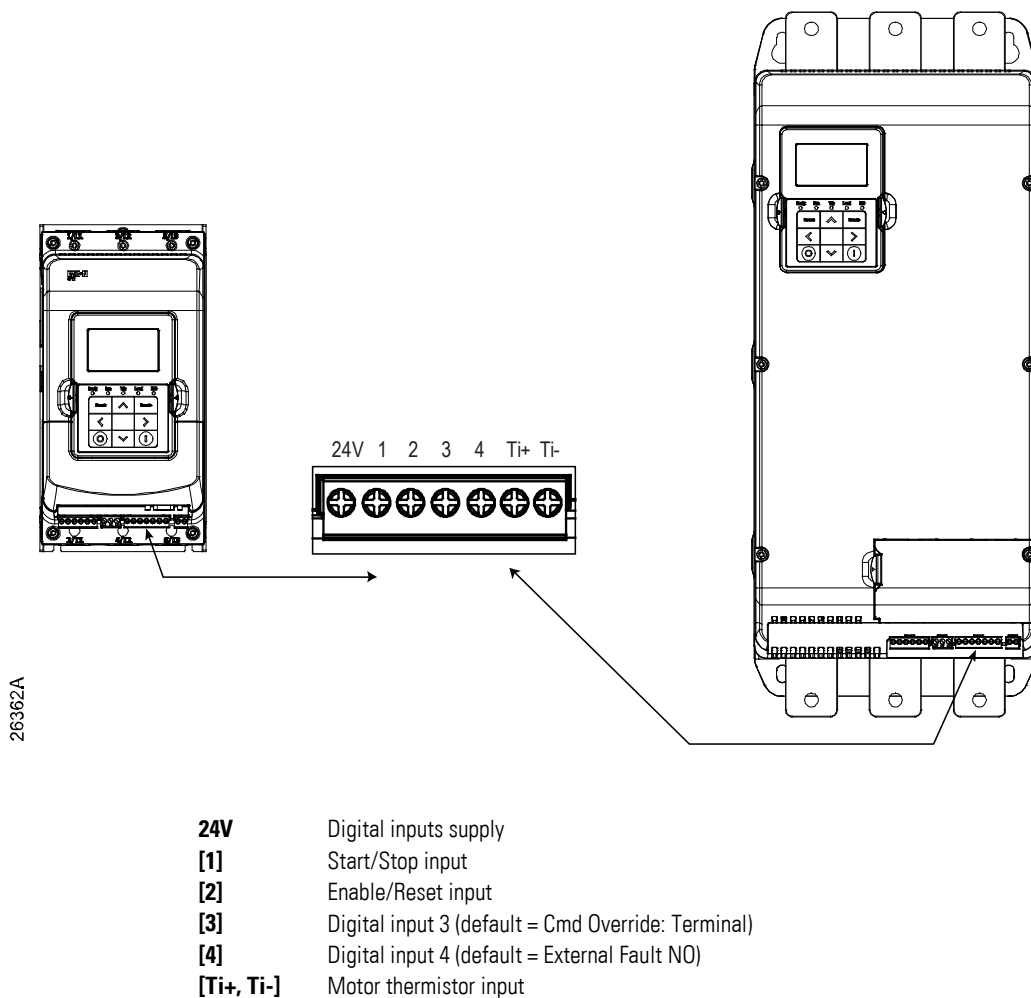

Figure 9: Input terminals

### 4.3.2 Motor thermistor

Motor thermistors can be connected directly to the soft starter. The soft starter will go into fault state when the resistance of the thermistor circuit exceeds approximately 3.6 k $\Omega$  or falls below 1.6  $\Omega$ .

The thermistors must be wired in series. The thermistor circuit should be run in screened cable and must be electrically isolated from earth and all other power and control circuits.

→ The thermistor input is disabled by default, but activates automatically when a thermistor is detected. If thermistors have previously been connected to the soft starter but are no longer required, use the Thermistor Reset function to disable the thermistor. Access 'Thermistor Reset' via the 'Tools' menu.

### 4.3.3 Enable/Reset

The Enable/Reset input [2] is normally closed by default. The soft starter will not perform a start if the Enable/Reset input is not in the correct state. The display will show 'Not Ready – Enable Input'.

If the Enable/Reset input changes state while the soft starter is running, the starter will remove power and allow the motor to coast to stop.

→ The Enable/Reset input can be configured for normally open or normally closed operation. Use parameter P7.13 Enable/Reset Logic.

## 4 Installation

### 4.3 Inputs

#### 4.3.4 Start/stop

The soft starter requires two-wire control.

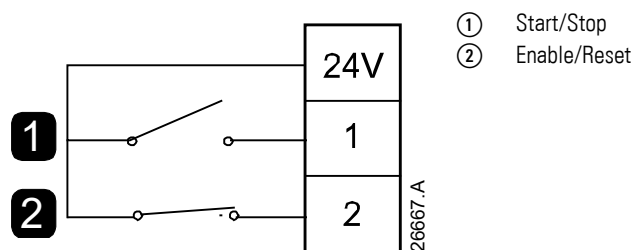

Figure 10: Two-wire control



#### **WARNING**

If the start input is closed when control voltage is applied, the starter will attempt to start.

Check that the Start/Stop input is open before applying control voltage.



The soft starter will only accept commands from the digital inputs if parameter P1.4 Command Source is set to 'Terminal'.

To allow the starter to enter Ready state so that it can accept a start command, the Enable/Reset input must be in the state set by parameter P7.13 Enable/Reset Logic.

- If the Enable/Reset input is not in the correct state, the starter will display 'Not Ready – Enable Input'.
- To initiate a start any time the starter is in Ready state, the Start/Stop input must be closed, and remain closed for as long as the motor needs to operate.
- To initiate a stop any time the starter is starting or running, the Start/Stop input must be opened.



#### **WARNING**

If the Start/Stop input is left closed after a fault occurs, while a lockout delay is in progress, or when control power is removed, a start will happen as soon as the starter returns to Ready state. This may result in unexpected machine operation.

### 4.3.5 Programmable digital inputs

The programmable inputs ([3] and [4]) allow external equipment to control the starter.

The operation of the programmable inputs is controlled by parameters P7.1~P7.13.

## 4.4 Outputs

### 4.4.1 Output terminals

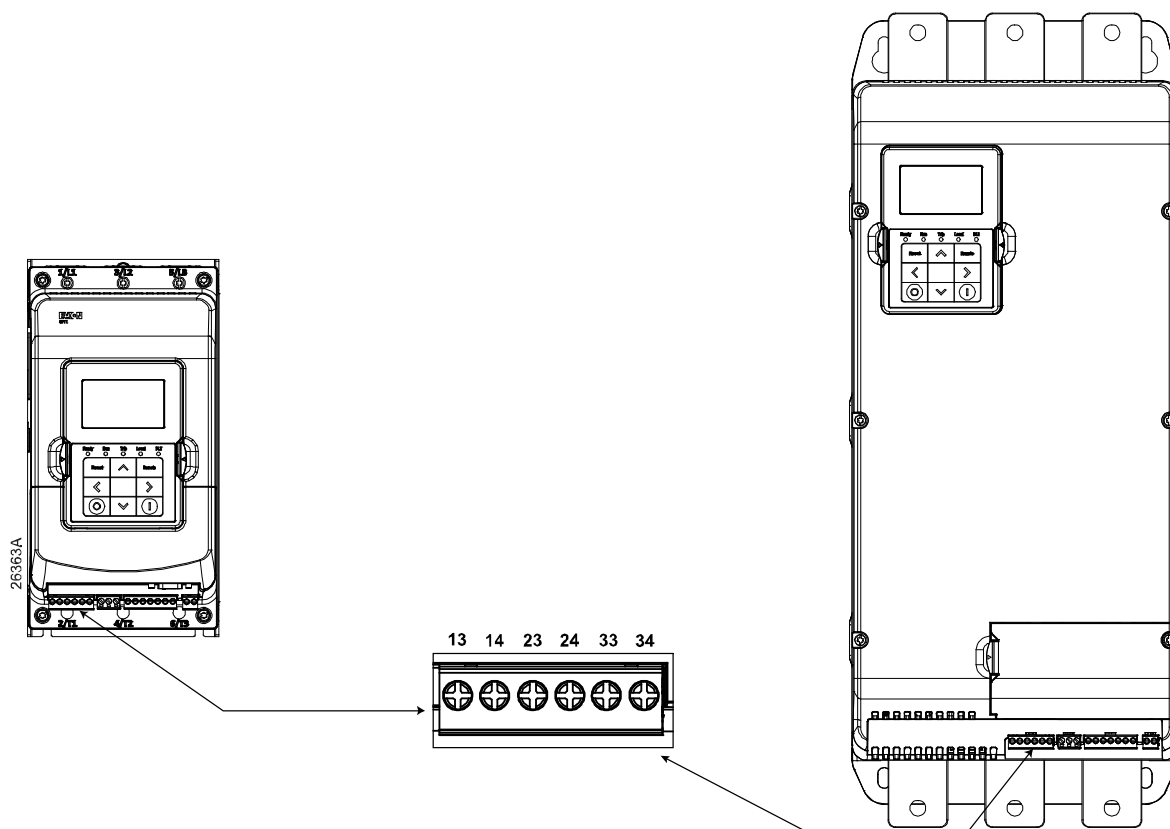

- [13, 14]** Main contactor output
- [23, 24]** Relay output 2 (default = Bypassed)
- [33, 34]** Relay output 3 (default = Fault)

Figure 11: Output terminals

## 4 Installation

### 4.4 Outputs

#### 4.4.2 Main contactor output

The main contactor output [13, 14] closes as soon as the soft starter receives a start command and remains closed while the soft starter is controlling the motor (until the motor starts a coast to stop, or until the end of a soft stop). The main contactor output will also open if the soft starter has an active fault.

The main contactor output can also be used to control a shunt trip circuit breaker.

➔ Use parameter P20.6 Shunt Trip Mode to configure the soft starter for use with a main contactor or circuit breaker.

- For use with a main contactor, use the default setting of 'Disable'
- For use with a circuit breaker, set P20.6 to 'Enable'

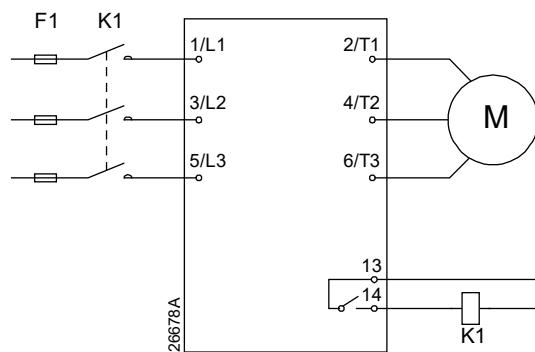

**F1** Fuses  
**K1** Main contactor

Figure 12: Soft starter installed with main contactor

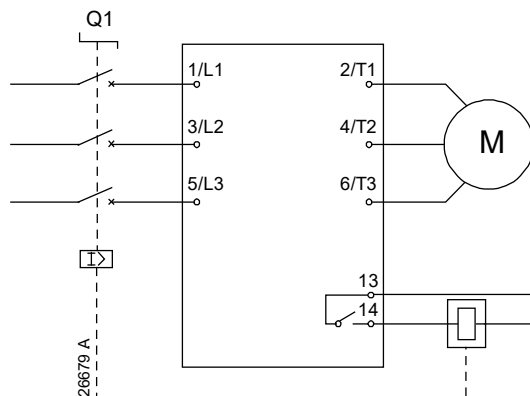

**Q1** Circuit breaker

Figure 13: Soft starter installed with a shunt relay and circuit breaker

**CAUTION**

Some electronic contactor coils are not suitable for direct switching with PCB mount relays. Consult the contactor manufacturer/supplier to confirm suitability.

### 4.4.3 Programmable relay outputs

The programmable relay outputs ([23, 24] and [33, 34]) can report the status of the starter, or can be used to control associated equipment.

The operation of the programmable outputs is controlled by parameters P8.1~P8.9.

## 4.5 Control voltage

- S711-34...AC (110~240 V AC): N, L
- S711-34...DC (24 V DC): -, +

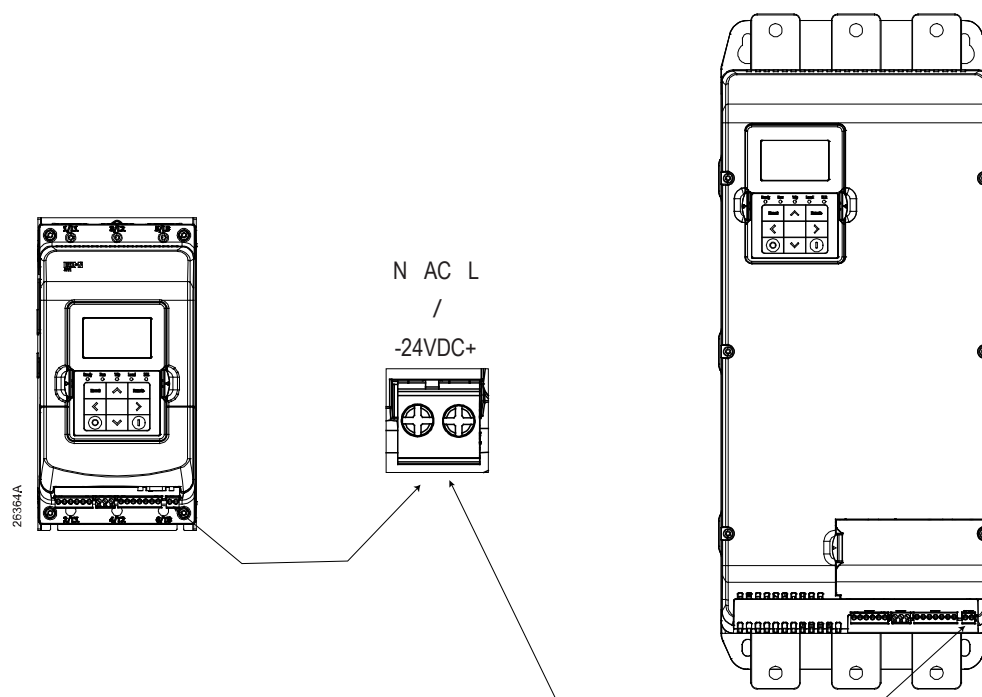

Figure 14: Control voltage terminals

Install supplementary or branch overcurrent protection on the control circuit supply (AC: N, L; DC: -, +), in accordance with the electrical code applicable at the installation location.

## 4 Installation

### 4.6 On-board Modbus RTU

#### 4.6 On-board Modbus RTU

Use terminals A, B, COM for on-board Modbus RTU connections.

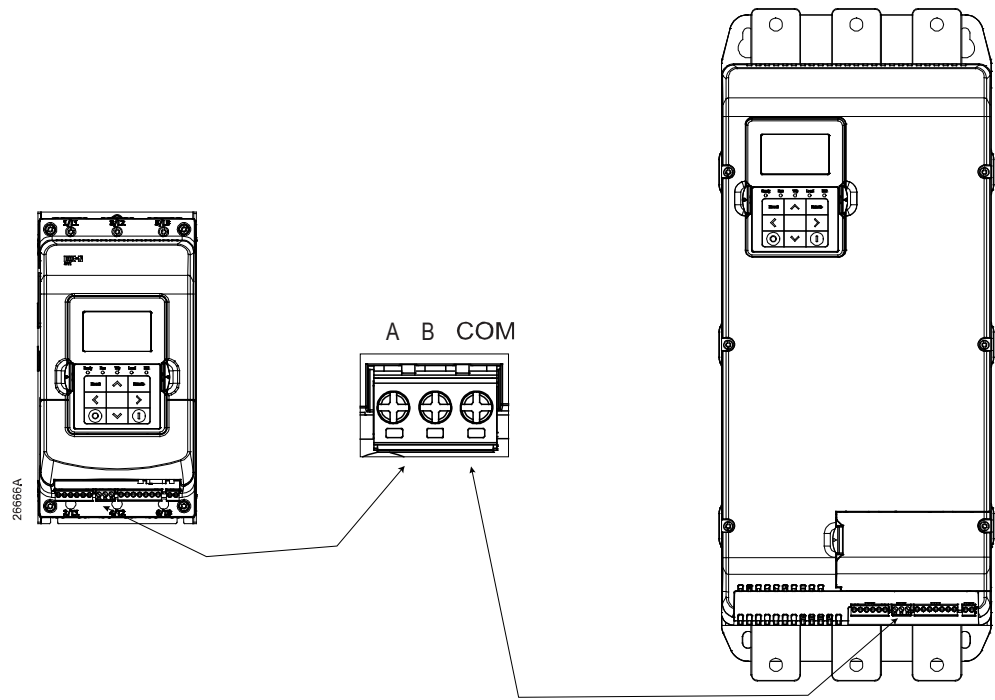

Figure 15: On-board Modbus RTU terminals

The terminals are labelled as per the standard TIA EIA-485/Modbus RTU. A is negative with respect to B for a binary 1 (OFF STATE); A is positive with respect to B for a binary 0 (ON STATE).

## 4.7 Power terminations

For all models the power input is at the top and the output is at the bottom of the unit.

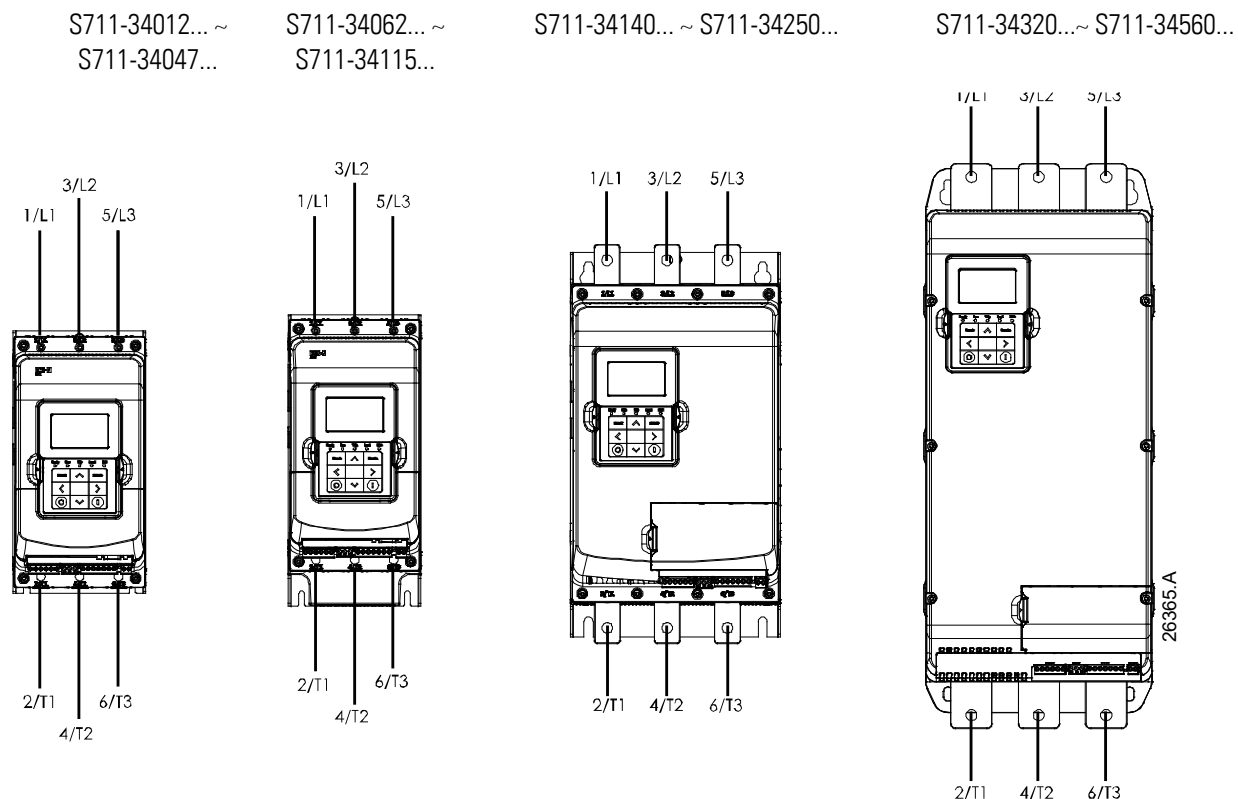

Figure 16: Power terminations

- Models S711-34012...~S711-34115... use cage clamps. Use only copper stranded or solid conductors, rated for 75 °C or higher, and stripped and terminated with a ferrule.
- Models S711-34140...~S711-34560... use busbars. Use copper or aluminium conductors, stranded or solid, rated for 60 °C/75 °C, and appropriate lugs.

## 4 Installation

### 4.7 Power terminations

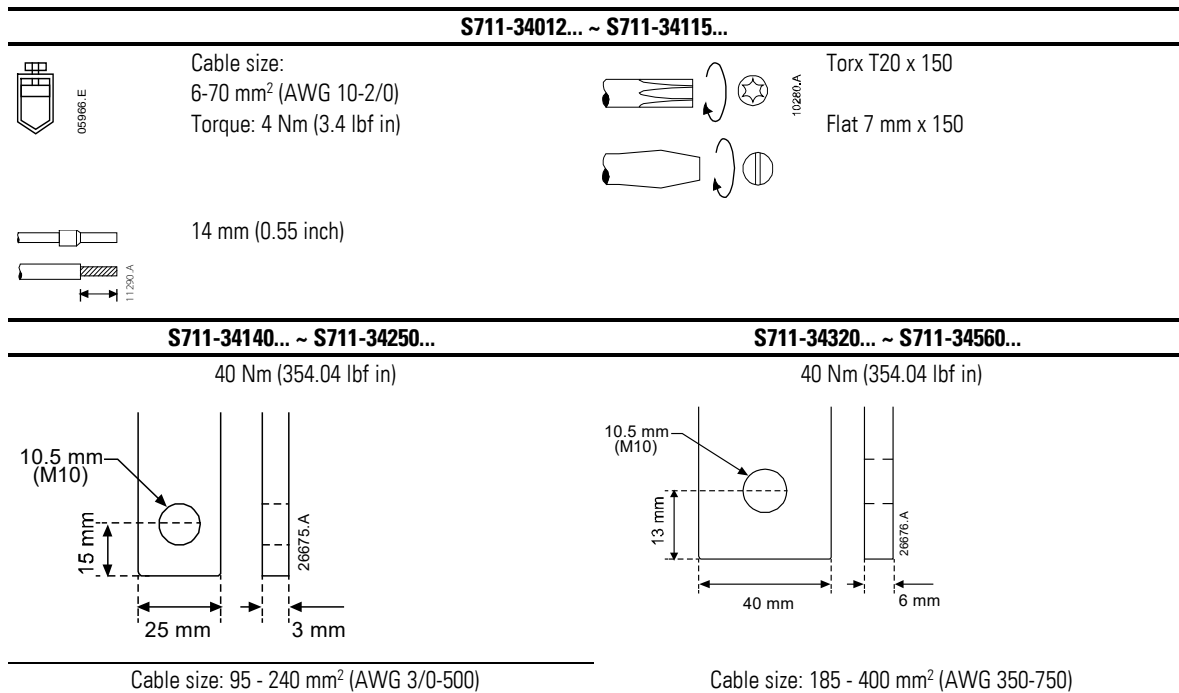

Figure 17: Cable size and torque

- ➔ Cable sizes are examples only: the size depends on the motor current and the cable length required.
- ➔ If the installation requires large diameter cables, it is possible to complete each termination with two smaller cables, one on each side of the busbar.
- ➔ When connecting power terminations, we recommend cleaning the surface contact area thoroughly (using an emery cloth or stainless steel brush) and using an appropriate jointing compound to prevent corrosion.

### 4.7.1 Wiring connectors

Select a connector according to the wire size, material and your application requirements.

A compression connector is recommended for models S711-34140 to S711-34560. The recommended crimping tool is TBM8-750.

Table 14: Wiring connectors

<b>Model</b>	<b>Example connector – aluminium cable</b>	<b>Example connector – copper cable</b>
S711-34140...	61148	60144
S711-34170...	61162	
S711-34210...	61165	60151
S711-34250...	61171	60160
S711-34320...		60166
S711-34410...	61178	60171
S711-34480...		60174
S711-34560...		60178
S711-34560...		60178

## 4 Installation

### 4.8 Motor connection

#### 4.8 Motor connection

The soft starter can be connected to the motor either in-line or inside delta (also called three-wire and six-wire connection). When connecting in inside delta, first set P2.5 Motor Connection to 'Inside Delta', then enter the motor full load amperage (FLA) for P2.1 Motor FLA and the motor nameplate power for P2.2 Motor Power.

##### 4.8.1 In-line installation, internally bypassed

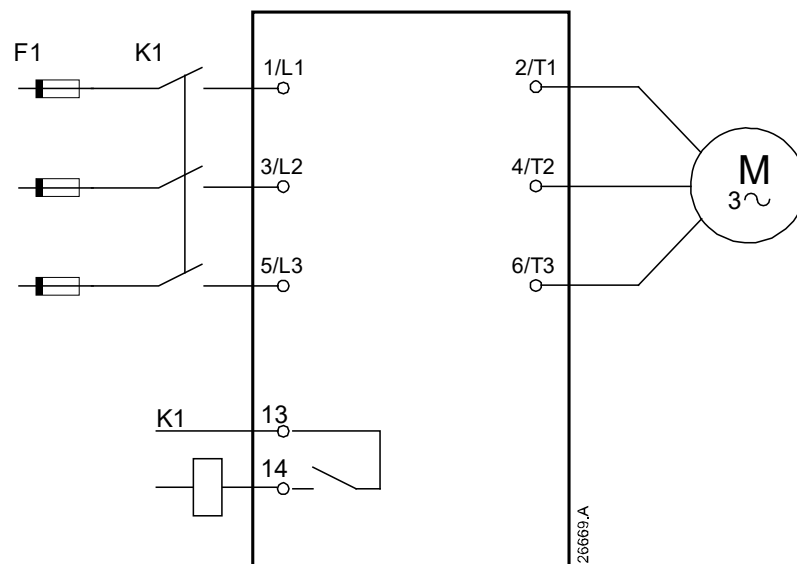

- K1** Main contactor (strongly recommended)
- F1** Fuses or circuit breaker
- [13, 14]** Main contactor output

Figure 18: In-line installation, internally bypassed

### 4.8.2 Inside delta installation, internally bypassed

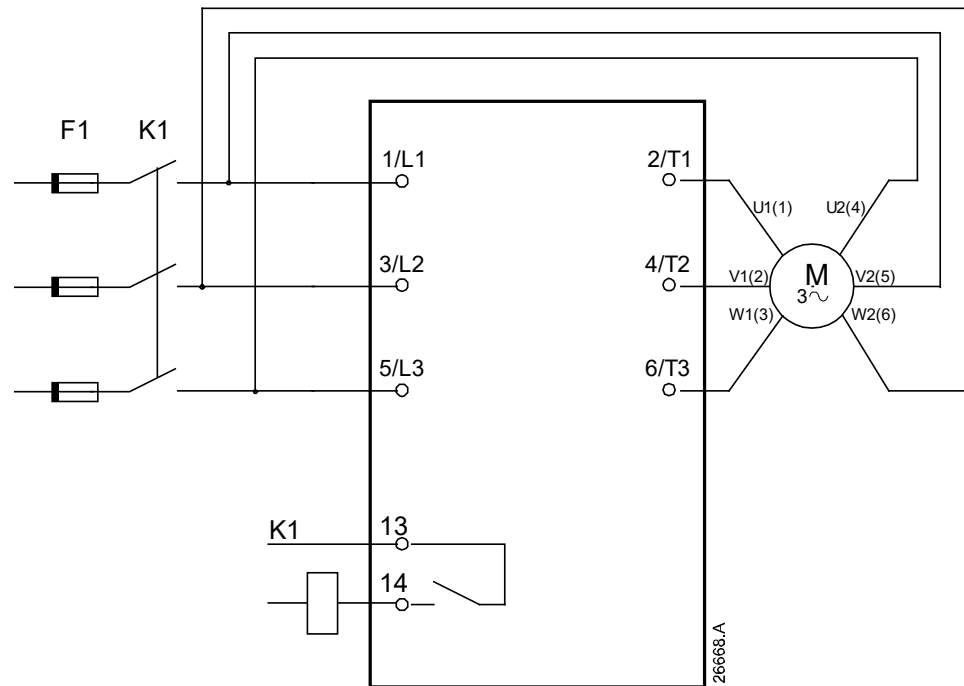

- K1** Main contactor  
**F1** Fuses or circuit breaker  
**[13, 14]** Main contactor output

Figure 19: Inside delta installation, internally bypassed

**WARNING**  
 When connecting the soft starter in inside delta configuration, always install a main contactor or shunt trip circuit breaker.

➔ When connecting in inside delta, first set P2.5 Motor Connection to 'Inside Delta', then enter the motor full load amperage (FLA) for P2.1 Motor FLA and the motor nameplate power for P2.2 Motor Power.

➔ If a keypad with FLA configured for inside delta connection is installed on a starter configured for in-line connection, the FLA may exceed the in-line starter's rating. The fault message 'FLA Too High' will be displayed.

## 4 Installation

### 4.9 Earth terminations

#### **4.9 Earth terminations**

Models S711-34012...~S711-34250... have a single earth terminal located at the top of the starter, between the two fixture holes.

Models S711-34320...~S711-34560... do not require a protective earth connection. All internal conductive parts are fully enclosed by a non-conductive outer case.

## 4.10 Typical installation

### 4.10.1 Internally bypassed installation

The soft starter is installed with a main contactor (AC-3 rated). Control voltage must be supplied from the input side of the contactor.

The main contactor is controlled by the main contactor output [13, 14].

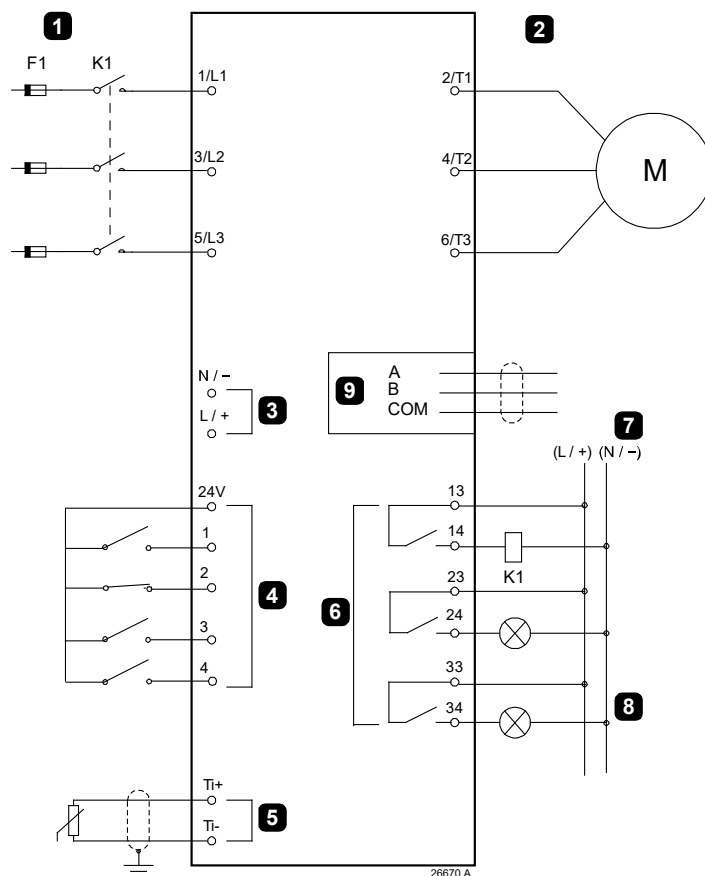

- |           |                                      |                   |  |
|-----------|--------------------------------------|-------------------|--|
| ①         | Three-phase supply                   | <b>24V</b>        | Digital inputs supply                              |
| ②         | Motor                                | <b>[1]</b>        | Start/Stop input                                   |
| ③         | Control voltage (soft starter)       | <b>[2]</b>        | Enable/Reset input                                 |
| ④         | Digital inputs                       | <b>[3]</b>        | Digital input 3 (default = Cmd Override: Terminal) |
| ⑤         | Motor thermistor input               | <b>[4]</b>        | Digital input 4 (default = External Fault NO)      |
| ⑥         | Relay outputs                        | <b>[Ti+, Ti-]</b> | Motor thermistor input                             |
| ⑦         | Control voltage (external equipment) | <b>[13, 14]</b>   | Main contactor output                              |
| ⑧         | Pilot lamps                          | <b>[23, 24]</b>   | Relay output 2 (default = Bypassed)                |
| ⑨         | Modbus RTU                           | <b>[33, 34]</b>   | Relay output 3 (default = Fault)                   |
| <b>K1</b> | Main contactor                       | <b>A, B, COM</b>  | Modbus RTU   |
| <b>F1</b> | Fuses or circuit breaker             |                   |  |

Figure 20: Internally bypassed installation

## 5 Keypad and feedback

### 5.1 The keypad

## 5 Keypad and feedback

### 5.1 The keypad

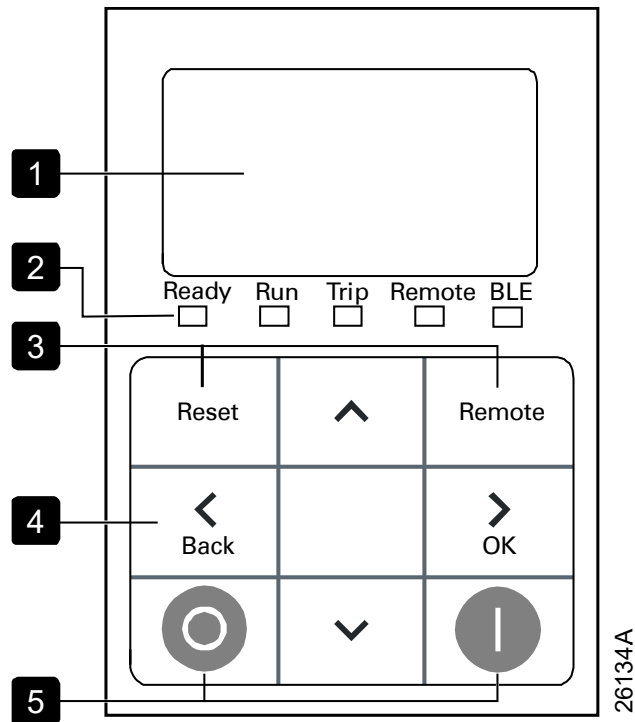



- ① Four-line display for status and programming details.
- ② Status LEDs
- ③ RESET: Reset a fault.  
REMOTE: Shortcut to P1.4 Command Source.
- ④ Menu navigation buttons:
  - ◀: Exit the menu or parameter, or cancel a parameter change.
  - ▶: Enter a menu or parameter, or save a parameter change.
  - ⬆ ⬇: Scroll to the next or previous menu or parameter, change the setting of the current parameter or scroll through the status screens.
- ⑤  /  : Use these buttons to stop and start the motor, respectively.

Figure 21: The keypad



For the soft starter to accept start commands from the keypad:

- parameter P1.4 Command Source must be set to 'Keypad'
- the keypad must be showing any display screen other than the Main Menu.

The soft starter always accepts stop and reset commands from the keypad, independent of parameter P1.4 Command Source.

## 5.2 Removable keypad

The keypad on the starter can be detached. You can use it directly on the starter or unclip it and mount it remotely, connecting it to the starter with a patch cable (up to 3 metres away from the starter). For instance, you can mount it on the front of the panel.

When the keypad is disconnected, it cannot control the starter.

If the motor is operating when the keypad is disconnected, the starter faults to de-energise the motor and put it into a safe state.

If the starter is in 'Ready' state when the keypad is disconnected, the motor is already in a safe (de-energised) state, and the starter faults.

In both cases:

- The Trip LED in the keypad recess flashes to indicate the fault.
- The starter returns a Modbus error code 04 (Slave Device Failure) to any Modbus request.

For more information, see Starter LEDs on page 153.

If removed, the RJ45 keypad connector must be re-fitted correctly. Insert the end with the clip [1] into the starter.

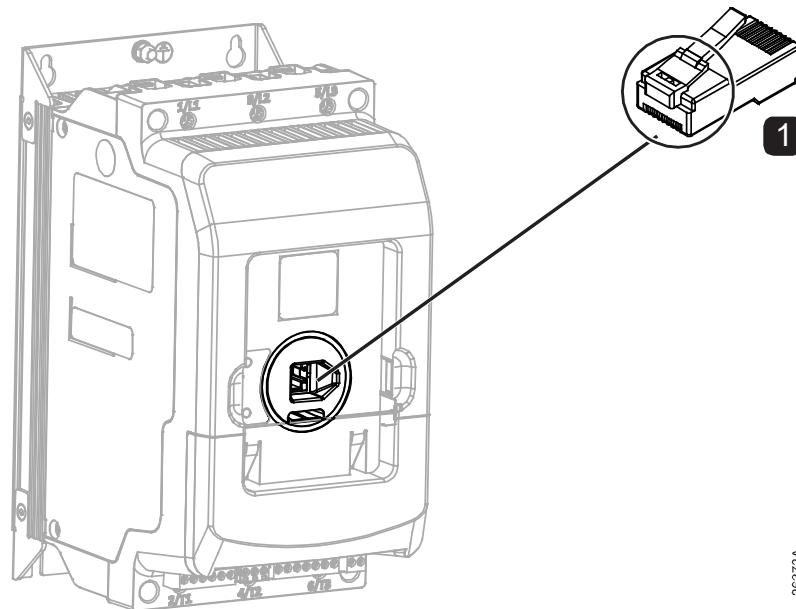

1 RJ45 keypad connector

Figure 22: Removable keypad connection

## 5 Keypad and feedback

### 5.3 Status LEDs

#### 5.3 Status LEDs

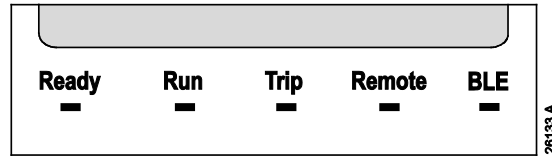

Figure 23: Status LEDs

LED name	On	Flashing	Off
Ready (green)	The motor is stopped and the starter is ready to start.	The motor is stopped and the starter is not ready to start: <ul style="list-style-type: none"> <li>Waiting for the Restart Delay (P5.24)</li> <li>Time between starts</li> <li>Starts per hour</li> <li>The starter has detected a motor overload, which is not yet cleared.</li> <li>The Enable/Reset input [2] is in the opposite state to that set in P7.13 Enable/Reset Logic.</li> </ul>	--
Run (green)	The motor is in Run state (receiving full voltage).	The motor is starting or stopping.	--
Trip (red)	The starter is in fault state.	The starter is in Warning state.	--
Remote (green)	<ul style="list-style-type: none"> <li>P20.7 Remote LED Mode is set to Terminal Control, 'Fieldbus Control' (on-board Modbus RTU or plug-in communication card) or 'Bus or Terminal Control'.</li> </ul> And <ul style="list-style-type: none"> <li>P1.4 Command Source is set to 'Terminal', 'On-board Modbus RTU' or 'ComCard'.</li> </ul>	--	P1.4 Command Source is set to 'Keypad'.
BLE (blue)	The starter is paired to the mobile app.	Bluetooth is enabled, not paired.	--

If all LEDs are off, the starter is not receiving control voltage.

## 5.4 Menu map

This menu map details all the screens and how to navigate to each of them. Each screen is detailed in the following chapters.

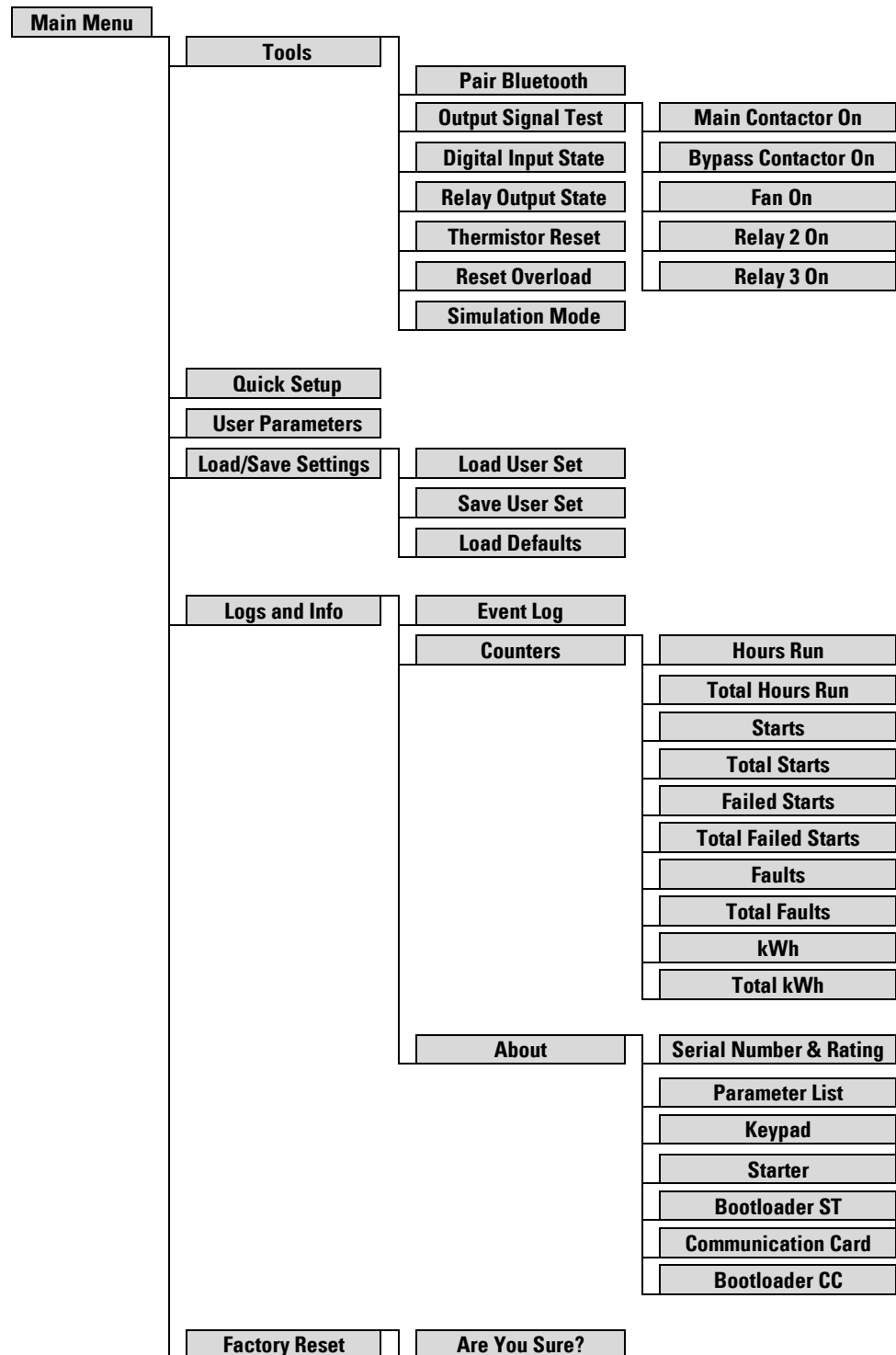

Figure 24: Menu map

## 5 Keypad and feedback

### 5.5 Displays

#### 5.5 Displays

The keypad displays a wide range of performance information about the soft starter. To scroll through the screens, press the  $\blacktriangle$  and  $\blacktriangledown$  buttons.

##### 5.5.1 Welcome

At power-up, the 'Welcome' screen briefly shows details of the main starter software versions as well as the starter's model.

```
Eaton
01.00/01.00
S711-34012AC
```

Software versions: keypad, starter  
Model code

Figure 25: Welcome screen

##### 5.5.2 Starter status

```
Running
69.0A          415V
               69.0A
```

Starter state  
Parameters P9.9 User Monitor 1 and P9.10  
User Monitor 2  
Motor running current

Figure 26: Starter status screen

##### 5.5.3 Phase currents

The current monitoring screen shows real-time line current on each phase.

```
Phase Currents
0000.0 0000.0 0000.0
        0000.0A
```

Figure 27: Phase currents screen

##### 5.5.4 Last start information

The last start information screen shows details of the most recent successful start:

- start duration (seconds)
- maximum start current drawn (as a percentage of motor full load amperage)
- calculated rise in motor overload percentage

```
M1 Started In:    010s
350%FLA          ΔTemp 5%
                0000.0A
```

Figure 28: Last start information screen

### 5.5.5 User configurable screen

This screen can be configured to show the most important information for the particular application. Use P9.11 ~ P9.14 to select which information to display.

Mains Frequency	59.7Hz
Power Factor	0.95
Motor Power	37.0kW
Motor Overload	%

Figure 29: User configurable screen

### 5.5.6 Performance graph

The performance graph provides a real-time display of operating performance. Use parameters P9.5~P9.7 to format the graph.

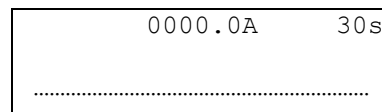

Figure 30: Performance graph screen (eg motor current)

Use P9.4 Graph Data to select what the graph displays:

- motor current
- line voltage
- motor overload
- motor pf

## 6 Tools

### 6.1 Pair Bluetooth

## 6 Tools

'Tools' includes options to pair via Bluetooth LE, test operation using the 'Output Signal Test', check status of the inputs and outputs, reset the thermistor status or the motor overload, and simulate starter functionality.

To access this menu:

Press **>** on the keypad, then press **>** again to open the 'Tools' menu.

See PIN number (password) protection on page 108 and P1.1 PIN Access Policy for details.

The default PIN is '000000'.



On first power up, 'Tools' is not available.

You can access the 'Tools' menu after configuring P1.1 PIN Access Policy. (Go to 'User Parameters'.)

If PIN protection is already active, 'Tools' access requires configuration using P20.1 to P20.4.

### 6.1 Pair Bluetooth

Use Tools > Pair Bluetooth to initiate a Bluetooth session with a mobile device running the app. See the S711 Connect App Instructions for details.

- When Bluetooth is enabled but pairing has not been established, the BLE LED flashes.
- Once the starter is paired via Bluetooth, the BLE LED turns blue and stops flashing.



The app is available for Android and iOS, from Google Play or the App Store.



To disable Bluetooth connection, set P1.2 BLE Access Policy to 'BLE Not Allowed'.

## 6.2 Output signal test

Use the 'Output Signal Test' to confirm that the soft starter and associated equipment have been installed correctly. This function enables manual control of each contactor and relay output. You can perform the following tests:

- Main Contactor On
- Bypass Contactor On
- Fan On
- Relay 2 On
- Relay 3 On



To test the main contactor or bypass contactor, the soft starter must be disconnected from the three-phase motor supply. If three-phase motor supply voltage is detected, an error message is displayed.

To test the fan or relays, the three-phase motor supply can be connected or disconnected.

This test is only available when the soft starter is in Ready state.

To use the 'Output Signal Test':

1. Press **>** on the keypad, then press **>** again to open the 'Tools' menu.
2. Scroll to 'Output Signal Test' and press **>**.
3. Scroll to select the item to test. Press **>** to activate the selected contactor or relay.  
The selected item will remain activated until the screen timeout occurs, if the user takes no further action.
4. Press **<** to deactivate the selected contactor or relay. Only one item can be activated at any time.
5. Press **<** to exit the test.
6. Press **<** to return to the 'Tools' menu.

6 Tools

6.3 Digital input state

**6.3 Digital input state**

This screen shows the Start/Stop, Enable/Reset and programmable inputs.

Start/Stop	(1)	0
Enable/Reset	(2)	1
Digital Input 3	(3)	0
Digital Input 4	(4)	0

**6.4 Relay output state**

This screen shows the fixed main contactor output, then programmable outputs 2 and 3.

Main Cont.	(13-14)	0
Relay 2	(23-24)	0
Relay 3	(33-34)	0

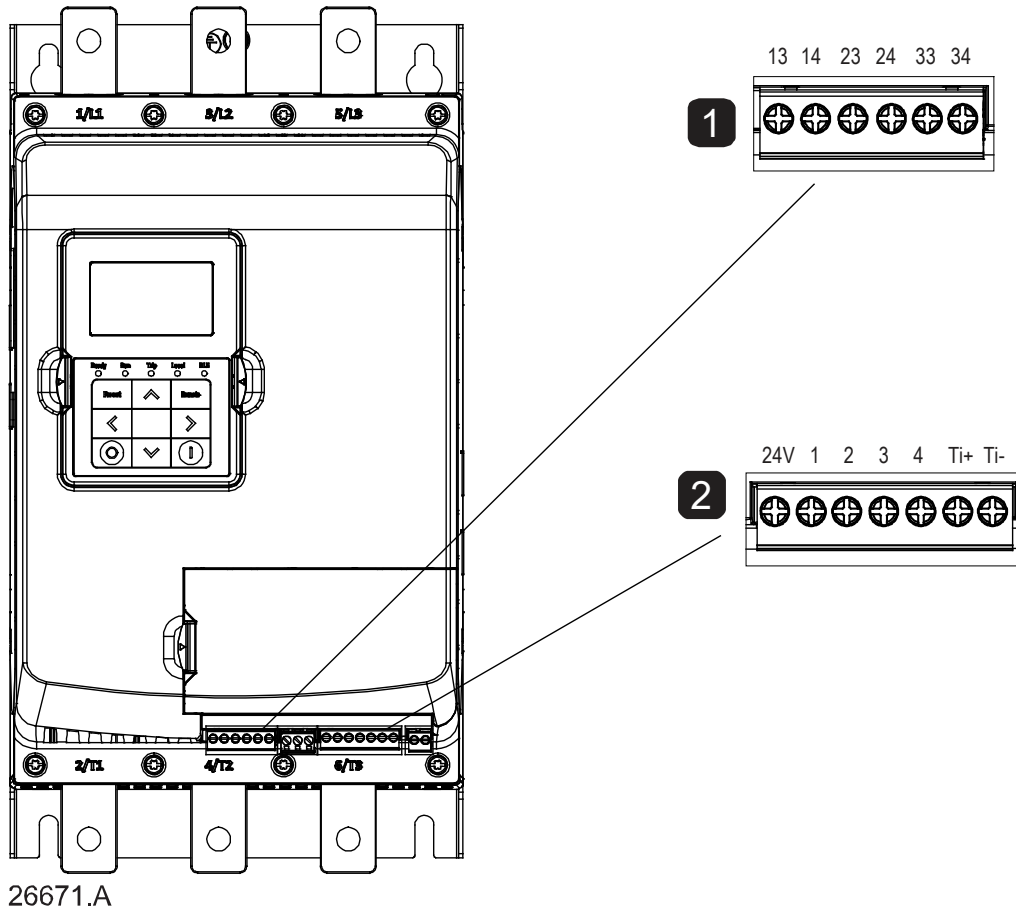

- ① Outputs
  - [13, 14]: Main contactor output
  - [23, 24]: Relay output 2
  - [33, 34]: Relay output 3

- ② Inputs
  - 24V: Digital inputs supply
  - [1]: Start/Stop input
  - [2]: Enable/Reset input
  - [3]: Digital input 3
  - [4]: Digital input 4

Figure 31: Digital IO state

## 6.5 Thermistor reset

The thermistor input is disabled by default, but activates automatically when a thermistor is detected. If thermistors have previously been connected to the soft starter but are no longer required, use the Thermistor Reset function to disable the thermistor.

## 6.6 Reset motor overload

When an overload is detected, the starter will respond as determined by parameter P5.31 Motor Overload. The 'Motor Overload' fault cannot be reset until the overload clears. The starter will be unable to attempt another start if there is insufficient overload capacity remaining.

The Reset Overload feature can be used to override a motor overload, in the event of an emergency.



### CAUTION

Resetting the motor overload will compromise protection and may compromise motor life. Only reset the motor overload in an emergency.

You can also reset the motor overload by cycling control power off then on.

## 6 Tools

### 6.7 Simulation mode

#### 6.7 Simulation mode

You can use 'Simulation Mode' for demonstration and training, and to test control wiring and parameter settings.

This mode emulates all soft starter functionalities, except Jog. It does not require a connected motor or three-phase motor supply.

Simulated data (voltage, current, etc) is available on any connected fieldbus and displayed on the keypad. You can test most protections against the simulated data by setting the appropriate thresholds.

The simulated voltage and frequency are fixed at 400 V AC and 50 Hz (these values are not adjustable). The simulated current is proportional to the setting of P2.1 Motor FLA, and will respond to parameters P3.4 Current Limit and P3.2 Start Ramp Time. The current will change over the duration of a simulated start or stop, as typically expected during normal operation.

To use 'Simulation Mode':

1. Press **>** on the keypad, then press **>** again to open the 'Tools' menu.
2. Scroll to 'Simulation Mode' and press **>**.
3. Scroll to 'Sim Mode Enable' and press **>**.
4. Press **<** to return to the 'Tools' menu.

When in simulation mode, 'Sim' appears in the lower left of the display screens.

To exit 'Simulation Mode':

1. Press **>** on the keypad, then press **>** again to open the 'Tools' menu.
2. Scroll to 'Simulation Mode' and press **>**.
3. Scroll to 'Sim Mode Disable' and press **>**.
4. Press **<** to return to the 'Tools' menu.



To use 'Simulation Mode', the soft starter must be disconnected from the three-phase motor supply. If three-phase motor supply voltage is detected, the simulation mode will not be activated, and an error message is displayed.

Simulation mode is only available when the soft starter is in Ready state.



#### **CAUTION**

If using the simulation mode in a live installation, you must isolate the soft starter from the three-phase motor supply. This isolation is typically upstream of the main contactor.



**CAUTION**

In simulation mode all IO will operate as configured, in response to starter state changes, faults, etc.

If any external plant or equipment is connected to the IO (especially the relay outputs), you must ensure that using 'Simulation Mode' will not result in dangerous or unexpected operation of that external equipment.

## 7 Quick setup

### 6.7 Simulation mode

## 7 Quick setup

'Quick Setup' makes it easy to configure the soft starter for common applications. The starter guides you through the most common installation parameters, and suggests a typical setting for the application. You must confirm or adjust each parameter to suit your exact requirements.

All other parameters remain at default values. To change other parameter values or review the default settings, use the menu (see Parameter list on page 111 for details).

Always set P2.1 Motor FLA to match the motor's nameplate full load amperage, and set P2.2 Motor Power to match the motor's nameplate power.

To access this menu:

Press **>** on the keypad, then scroll to 'Quick Setup' and press **>** again.

Table 15: Suggested application settings

Application	Start Mode	Start Ramp Time (seconds)	Initial Current (%)	Current Limit (%)	Pump Start Profile	Stop Mode	Stop Time (seconds)	Pump Stop Profile
Pump Centrifugal	Pump Control	10	n/a	500	Early accel.	Pump Control	15	Late decel.
Pump Bore	Pump Control	5	n/a	500	Early accel.	Pump Control	5	Late decel.
Pump Hydraulic	Constant Current	5	200	350	n/a	Coast To Stop	n/a	n/a
Fan Damped	Constant Current	5	200	350	n/a	Coast To Stop	n/a	n/a
Fan Undamped	Constant Current	10	200	450	n/a	Coast To Stop	n/a	n/a
Compressor Screw	Constant Current	5	200	400	n/a	Coast To Stop	n/a	n/a
Compressor Recip	Constant Current	5	200	450	n/a	Coast To Stop	n/a	n/a
Conveyor	Constant Current	10	200	450	n/a	Voltage Ramp	5	n/a
Bow Thruster	Constant Current	5	100	400	n/a	Coast To Stop	n/a	n/a
Bandsaw	Constant Current	10	200	450	n/a	Coast To Stop	n/a	n/a



The Pump Start Profile and Pump Stop Profile settings only apply when using pump control. The settings are ignored for all other start and stop modes.

## 8 Load/save settings

'Load/Save Settings' allows users to:

- Reset all parameters to factory default values
- Load parameter settings from an internal file
- Save the current parameter settings to an internal file

The internal file contains default values until a user file is saved.

To access this menu:

Press **>** on the keypad, then scroll to 'Load/Save Settings' and press **>** again.

To load or save parameter settings:

1. Press **>** to open the menu.
2. Scroll to Load/Save Settings and press the **>** button.
3. Scroll to the required function and press the **>** button.

Load/Save Settings
Load User Set
Save User Set
Load Defaults

4. At the confirmation prompt, select No to cancel or Yes to confirm, then press **>** to proceed.

Load Defaults
No
Yes

When the action has been completed, the screen will briefly display a confirmation message, then return to the previous menu level.

## 9 Logs and info

### 9.1 Event log

## 9 Logs and info

'Logs and Info' provides information on events, faults and starter performance. It also provides information on the software version the starter is currently running.

To access this menu:

Press **➤** on the keypad, then scroll to 'Logs and Info' and press **➤** again.

### 9.1 Event log

The event log stores details of the starter's most recent faults, warnings, and operations (including starts, stops and configuration changes).

Event 1 is the most recent and the event with the largest number is the oldest stored event. The log records the number of days since the event. A maximum of 1000 records can be stored in the event log.



The event log can be exported to an external file for analysis away from the starter. Use the S711 Connect app to download the logs. See the S711 Connect App Instructions for details.

### 9.2 Counters

The counters store statistics on the starter's operation:

- Hours run (lifetime and since counter last reset)
- Number of starts (lifetime and since counter last reset)
- Number of failed starts (lifetime and since counter last reset)
- Number of faults (lifetime and since counter last reset)
- Power used (lifetime and since counter last reset)

To view the counters:

1. Open the 'Logs and Info' menu.
2. Scroll to 'Counters' and press **➤**.
3. Use the **▲** and **▼** buttons to scroll through the counters. Press **➤** to view details.
4. To reset a counter, press **➤** then use the **▲** and **▼** buttons to select Reset/Do Not Reset. Press **➤** to confirm the action.

To close the counter and return to 'Logs and Info', press **◀**.

## 9.3 About screen

The 'About' screen reports the version of each software component in the starter:

- Serial Number & Rating
- Parameter List
- Keypad (firmware version)
- Starter (firmware version)
- Bootloader ST (firmware version)
- Communication Card (firmware version) (if fitted)
- Bootloader CC (firmware version)



Updated software can be loaded into the starter using the S711 Connect app if required. See the S711 Connect App Instructions.

### 9.3.1 Serial number and rating

	Serial Number & Rating
Product name	→ S711
Serial number	→ 123456-123
Model number	→ S711-34012...

### 9.3.2 Parameter list

	Parameter List
Parameter list version	→ 13.01

### 9.3.3 Keypad

	Keypad
Keypad firmware version	→ 01.00

### 9.3.4 Starter

	Starter
Starter firmware version	→ 01.00

### 9.3.5 Bootloader starter

	Bootloader ST
Bootloader starter firmware version	→ 01.00

## 9 Logs and info

### 9.3 About screen

#### 9.3.6 Communication card

Communication card firmware version, if fitted → 

Communication Card 00.00
-----------------------------

#### 9.3.7 Bootloader communication card

Bootloader communication card firmware version → 

Bootloader CC Not present
------------------------------

## 10 Factory Reset

The 'Factory Reset' menu allows you to reset all the parameters to the factory default settings. This is useful in case you have set up a PIN-restricted access and you have lost your PIN number.

**CAUTION**

This will reset all parameters and stored user sets to the factory defaults.

If you have made a backup, you can use the S711 Connect app to reload your parameter settings. See the S711 Connect App Instructions for details.

To access this menu:

1. Press **>** on the keypad, then scroll to 'Factory Reset' and press **>** again.
2. The next screen asks you to confirm your choice.
3. Press **>** to confirm, or **<** to cancel.

Factory Reset  
Are You Sure?

## 11 Cybersecurity

### 11.1 Starter defence in depth

## 11 Cybersecurity

This chapter documents the cybersecurity measures included within the device and provides guidance on its secure use. The aim of our cybersecurity measures is to minimise the impact of any one protection being bypassed. We outlined below what to do to keep your device (the starter) secure and explain the security features to minimise the risk of successful cybersecurity attacks.

Before you read this chapter, we recommend you become familiar with our Best Practice document and other cybersecurity related information at [eaton.com](http://eaton.com).

### 11.1 Starter defence in depth

Our security Defence in Depth (DiD) strategy supports the installation, operation and maintenance of the starter. Your system is safeguarded against cybersecurity attacks by deploying multiple layers of security defence, including plant security, network security and system integrity.

### 11.2 Plant security

Plant security incorporates site specific actions such as protecting equipment and following security policies. The protection of equipment can be achieved by compensating countermeasures, such as housing the starter in a locked cabinet, enclosing cabling in protected conduits and controlling physical access via locked gates to protect your site against unauthorised access.

### 11.3 Network security



#### **CAUTION**

Do not use an insecure network.

We recommend that you keep your network area secure by utilising firewalls and micro-segmentation software that applies network virtualisation. See 9.3 CR 5.1 – Network segregation in IEC 62443-4-2 for further information on segregation.

The fieldbus connections (on-board Modbus RTU and other Ethernet cards) are intended to be connected to an operational technology (OT) network, which is segmented from other networks, with at least firewall protection to mitigate cyber threats and to prevent exposure to access via the internet.

## 11.4 System integrity

The security of the system itself is the joint responsibility of all stakeholders, including operators, service providers and system integrators, to ensure cybersecurity protection is upheld.

The starter's configuration settings are set to the most protected state possible with the cybersecurity features enabled. We recommend that you take the following actions as soon as possible after receiving the starter:

- Use PIN numbers to restrict access to the starter tools and limit parameter editing (see P1.1 PIN Access Policy, and P20.1 to P20.4 to set the PIN access rights and PIN numbers).
- On-board Modbus RTU is enabled by default. Use parameter P10.8 Fieldbus Select to disable fieldbus if it is not required.
- Fit an Ethernet device (only if required) and connect to an appropriately secured network (see the User Manual for the relevant Ethernet card for details).
- Use parameter P10.8 Fieldbus Select to select the required mode.
- Enable Bluetooth (only if required), and select 'BLE Secure Pairing' instead of 'BLE Auto Pairing' (see P1.2 BLE Access Policy).



### CAUTION

Modbus RTU is enabled by default. We strongly recommend that you use Safety Instrumented Systems (SIS) along with this component.

We provide a number of important key features to ensure system integrity:

- PIN number protection
- Digitally signed firmware
- Secure Bluetooth pairing

### 11.4.1 PIN number protection

See PIN number (password) protection on page 108 for details.



### CAUTION

It is optional to use the PIN number protection cybersecurity feature.

However, we strongly advise against disabling the PIN number as it will greatly increase vulnerability of the starter to cyber attack.

## 11 Cybersecurity

### 11.5 Firmware updates

#### 11.4.2 Digitally signed firmware

The overall system security is enhanced by the digitally signed firmware process that helps to protect against alterations from unauthorised parties, malware injection, and other security threats.

This system is intended to ensure that only code originating and unchanged from the vendor can be installed on the starter.

All firmware updates are digitally signed to ensure authenticity before being programmed into the starter.

#### 11.4.3 Secure Bluetooth pairing

When 'BLE Secure Pairing' is enabled (see P1.2 BLE Access Policy), Bluetooth pairing between the starter and the S711 Connect app is initiated when you input a 6-digit code (pass key) randomly generated by the starter (displayed on the starter keypad). It differs for each Bluetooth pairing session and is unique to your device. This ensures that the starter cannot automatically pair with any other Bluetooth devices even if they are within range. The Bluetooth Low Energy facility will turn off when the session ends, the phone moves out of range or the connection drops.

See the S711 Connect App Instructions for specific details on how to securely connect using Bluetooth.

### 11.5 Firmware updates

Firmware updates are published and can be downloaded from the mobile phone app. These updates may address security issues found in the starter including vulnerabilities. We recommend that you regularly monitor the app and apply firmware updates as they are released.

### 11.6 Vulnerabilities

Vulnerabilities are notified to a Common Vulnerabilities and Exposures (CVE) Numbering Authority (CNA) and also published on [eaton.com](http://eaton.com).

#### 11.6.1 Decommissioning guidelines

The process of securely decommissioning the starter involves physically destroying and disposing of the starter.



Perform a factory reset to remove all configuration data and restore your starter to the factory default settings. See Factory reset on page 81 for details.

## 12 Operation

### 12.1 Start, stop and reset commands

The soft starter can be started and stopped via the keypad, digital inputs, on-board Modbus RTU or communication card. The command source can be set using parameter P1.4 Command Source.

- The soft starter will only accept start commands from the designated command source.
- The soft starter will accept stop and reset commands from the keypad, independent of the command source.
- The soft starter will accept stop commands from the designated command source, and can be forced to stop by activating the Enable/Reset input (see parameter 7.13 Enable/Reset Logic).
- A programmable input can be used to override the selected command source (see parameter P7.1 Input 3 Function).
- The soft starter will accept reset commands from the programmable input, independent of the command source.

### 12.2 Command override

The programmable input [3] can be used to override the command source, for situations where the normal control mechanism has been lost. Set parameter P7.1 Input 3 Function to an alternative command source (eg 'Cmd Override: Keypad').

While the input is active, the starter will only accept commands from the selected override source. To restore control to the command source selected in parameter P1.4 Command Source, re-open the input.

- The soft starter will accept reset commands from the programmable input, independent of the command source.

## 12 Operation

### 12.3 Two-phase control

#### 12.3 Two-phase control

Two-phase control allows the soft starter to control the motor in the event it has a damaged phase (this could be due to a shorted SCR or a welded bypass contactor). The soft starter will use two-phase control mode to soft start and soft stop the motor.

Two-phase control does not support pump control soft starting or soft stopping. In 'Two-phase Control', the soft starter will use constant current soft starting and timed voltage ramp soft stopping. If 'Two-phase Control' is enabled in P6.5 Shorted SCR Action, parameters P3.3 Initial Current and P3.4 Current Limit must be set appropriately.

➔ The starter will activate the fault 'Lx-Tx Shorted' on the first start attempt after control power is applied. Two-phase control will not operate if control power is cycled between starts.

- Two-phase control is only available with in-line installations. If the starter is installed inside delta, two-phase control will not operate.
- Two-phase control remains active until 'Two-phase Control' is deselected or control power is removed. While operating in two-phase control, the trip LED will flash and the screen will display '2 Phase – Damaged SCR'.

➔ Two-phase control is intended only for emergency operation. We do not recommend its use in situations that require testing and/or compliance with specific standards as it is not certified.



#### **CAUTION**

Two-phase control uses a two-phase soft start technology and additional care is required when sizing circuit breakers and protection. Contact your local supplier for assistance.

## 12.4 Fire mode

Fire mode allows the soft starter to run the motor and ignore fault conditions.

Fire mode is controlled via a programmable input (input [3] or input [4]). Parameters P7.1 Input 3 Function or P7.7 Input 4 Function must be set to 'Fire Mode'. Parameter P20.11 Fire Mode Enable must be set to 'Enable'.

A closed circuit across [3] or [4] activates fire mode. When the soft starter receives a start command, it will continue to run until a stop command is received, ignoring most fault conditions ('Power Loss' and 'Phase Sequence' are not ignored).

Fire mode can be used in conjunction with any command source.

➔ To allow the starter to enter Ready state so that it can accept a start command, the Enable/Reset input must be in the state set by parameter P7.13 Enable/Reset Logic.

➔ In Fire mode, the starter only responds to start and stop commands. Only the starter status screen is visible.

➔ Fire mode is intended only for emergency operation. We do not recommend its use in situations that require testing and/or compliance with specific standards as it is not certified.



### CAUTION

Continued use of fire mode is not recommended. Fire mode may compromise the starter and/or motor life as all protections and faults are disabled.

**Using the starter in fire mode will void the product warranty.**

## 12 Operation

### 12.5 External fault

#### 12.5 External fault

An external fault circuit (such as a low pressure alarm switch for a pumping system) can be used to generate a fault in the soft starter and stop the motor. The external circuit is connected to a programmable input (input [3] or input [4]). To control the behaviour of the fault, set the following parameters:

- Parameter P7.1 Input 3 Function: select 'External Fault NO' or 'External Fault NC'.
- Parameter P7.2 Input 3 Fault: set as required. For example, 'Bypassed' limits the external fault to when the soft starter is bypassed.
- Parameter P7.4 Input 3 Fault Delay: sets a delay between the input activating and the soft starter entering fault state.
- Parameter P7.5 Input 3 Initial Delay: sets a delay before the soft starter monitors the state of the input, after the start signal. For example, a delay may be required to allow time for pipeline pressure to build up.
- Parameter 7.6 Input 3 Fault Name: accept the default or use the S711 Connect app to create a custom name.

## 12.6 Typical control methods

The requirements of an application differ between each installation, but the methods listed below are often a good starting point for common applications.

Table 16: Typical control methods

Application	Start Mode	Start Ramp Time (seconds)	Initial Current (%FLA)	Current Limit (%FLA)	Stop Mode	Stop Time (seconds)
Bow thruster	Constant Current	5	100	400	Coast To Stop	n/a
Centrifuge (separator)	Constant Current	1	200	450	Coast To Stop	n/a
Chipper	Constant Current	1	200	450	Coast To Stop	n/a
Compressor - reciprocating - loaded	Constant Current	1	200	450	Coast To Stop	n/a
Compressor - reciprocating - unloaded	Constant Current	1	200	400	Coast To Stop	n/a
Compressor - screw - loaded	Constant Current	1	200	400	Coast To Stop	n/a
Compressor - screw - unloaded	Constant Current	1	200	350	Coast To Stop	n/a
Conveyor - horizontal	Constant Current	5	200	400	Voltage Ramp	10
Conveyor - inclined	Constant Current	2	200	450	Coast To Stop	n/a
Conveyor - vertical (bucket)	Constant Current	2	200	450	Coast To Stop	n/a
Crusher - cone	Constant Current	1	200	350	Coast To Stop	n/a
Crusher - jaw	Constant Current	1	200	450	Coast To Stop	n/a
Crusher - rotary	Constant Current	1	200	400	Coast To Stop	n/a
Debarker	Constant Current	1	200	350	Coast To Stop	n/a
Fan - axial (damped)	Constant Current	1	200	350	Coast To Stop	n/a
Fan - axial (undamped)	Constant Current	1	200	450	Coast To Stop	n/a
Fan - centrifugal (damped)	Constant Current	1	200	350	Coast To Stop	n/a
Fan - centrifugal (undamped)	Constant Current	1	200	450	Coast To Stop	n/a
Fan - high pressure	Constant Current	1	200	450	Coast To Stop	n/a
Mill - ball	Constant Current	1	200	450	Coast To Stop	n/a
Mill - hammer	Constant Current	1	200	450	Coast To Stop	n/a
Pump - bore	Pump Control (Early accel.)	3	n/a	500	Pump Control (Late decel.)	3
Pump - centrifugal	Pump Control (Early accel.)	10	n/a	500	Pump Control (Late decel.)	15
Pump - Hydraulic	Constant Current	2	200	350	Coast To Stop	n/a
Pump - positive displacement	Pump Control (Const. accel.)	10	n/a	400	Pump Control (Const. decel.)	10
Pump - submersible	Pump Control (Early accel.)	5	n/a	500	Pump Control (Late decel.)	5
Saw - bandsaw	Constant Current	1	200	450	Coast To Stop	n/a
Saw - circular	Constant Current	1	200	350	Coast To Stop	n/a
Shredder	Constant Current	1	200	450	Coast To Stop	n/a

## 12 Operation

### 12.7 Soft start methods

#### 12.7 Soft start methods

##### 12.7.1 Constant current

Constant current is the traditional form of soft starting, which raises the current from zero to a specified level and keeps the current stable at that level until the motor has accelerated.

Constant current starting is ideal for applications where the start current must be kept below a particular level.

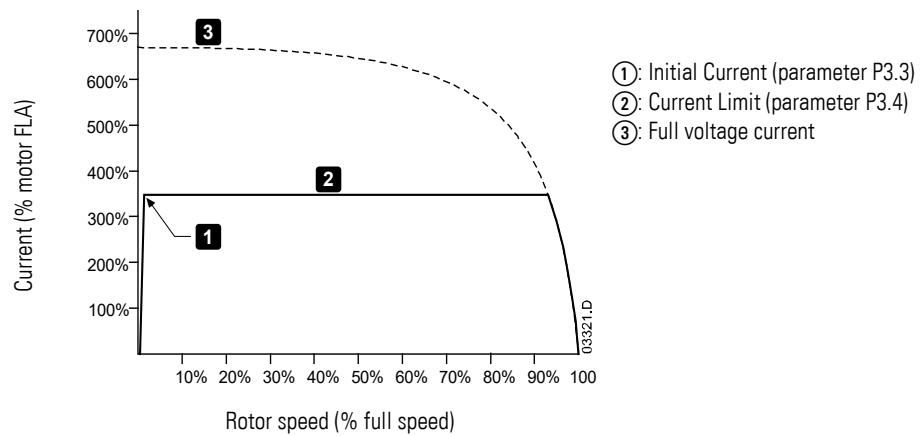

Figure 32: Constant current

### 12.7.2 Constant current with current ramp

Current ramp soft starting raises the current from a specified starting level (1) to a maximum limit (3), over an extended period of time (2).

Current ramp starting can be useful for applications where:

- the load can vary between starts (for example a conveyor which may start loaded or unloaded). Set the initial current (parameter P3.3) to a level that will start the motor with a light load, and the current limit (parameter P3.4) to a level that will start the motor with a heavy load.
- the load breaks away easily, but starting time needs to be extended (for example a centrifugal pump where pipeline pressure needs to build up slowly).
- the electricity supply is limited (for example a generator set), and a slower application of load will allow greater time for the supply to respond.

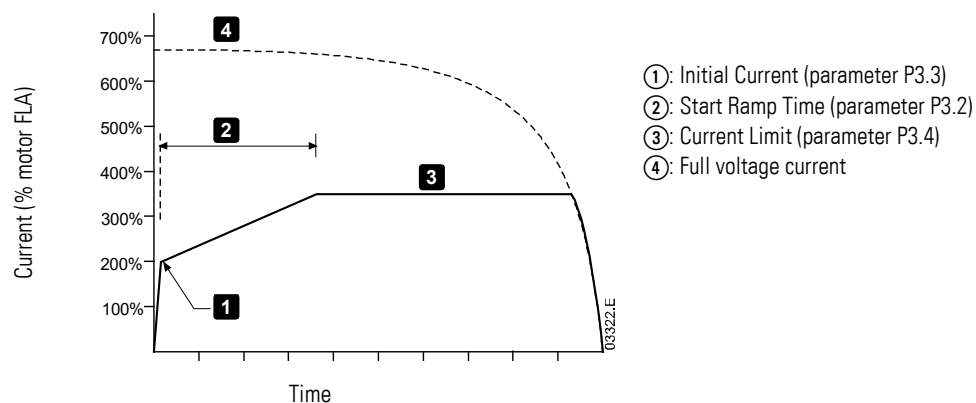

Figure 33: Constant current with current ramp

## 12 Operation

### 12.7 Soft start methods

#### 12.7.3 Constant current with kickstart

Kickstart provides a short boost of extra torque at the beginning of a start, and can be used in conjunction with current ramp or constant current starting.

Kickstart can be useful to help start loads that require high breakaway torque but then accelerate easily (for example helical rotor pumps).



Kickstart is not available when pump control start mode is selected.

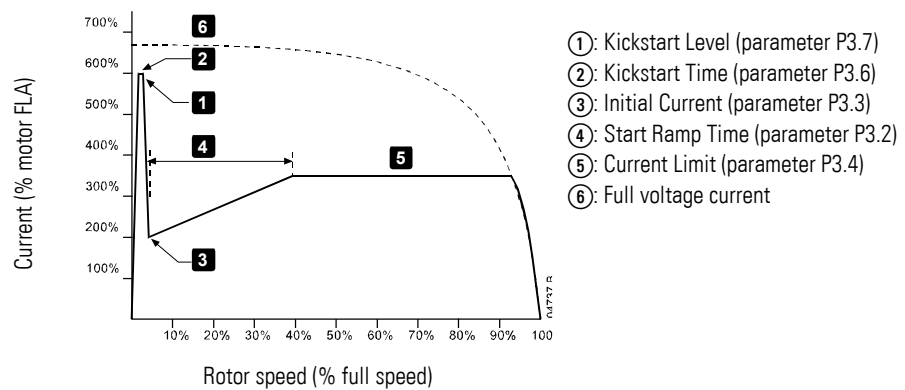

Figure 34: Constant current with kickstart

### 12.7.4 Timed voltage ramp

Timed voltage ramp (TVR) soft starting ramps the application of voltage to the motor over a defined time period. The voltage ramp reduces the initial starting torque and slows the motor's rate of acceleration.

TVR starting can be useful for applications where multiple motors of different sizes are connected in parallel, and/or the loads are not mechanically linked.

➔ TVR soft starting is not suitable for high inertia loads (such as fans), which require a high level of voltage to accelerate the load.

➔ For multiple motors of the same sizes, and/or mechanically coupled loads, use constant current starting.

For a timed voltage ramp start, the following are typical values and can be adjusted to suit your specific application:

- Add the FLA value of all the connected motors. Use this combined value to set P2.1 Motor FLA. (Note that the combined value must not exceed the starter rating.)
- Set P3.3 Initial Current to 100%, P3.4 Current Limit to 500%, and set the ramp time as required (P3.2 Start Ramp Time).

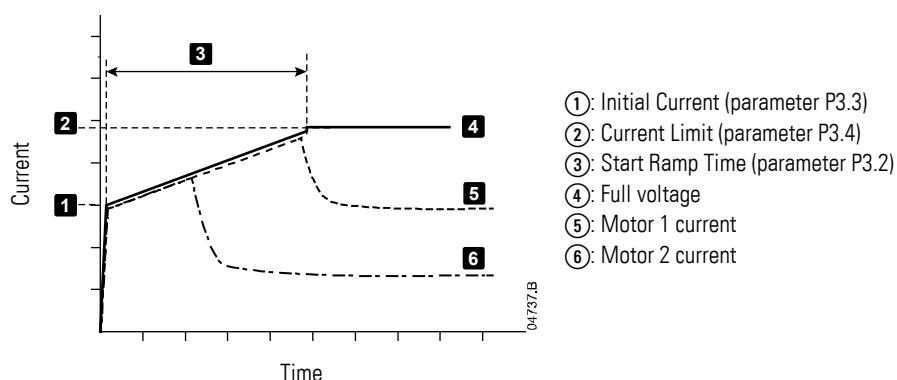

Figure 35: Timed voltage ramp

## 12 Operation

### 12.7 Soft start methods

#### 12.7.5 Pump control for starting

In a pump control soft start, the soft starter adjusts the current in order to start the motor within a specified time and using a selected acceleration profile.

➔ The soft starter will apply the current limit on all soft starts, including pump control. If the current limit is too low or the start ramp time is too short, the motor may not start successfully.

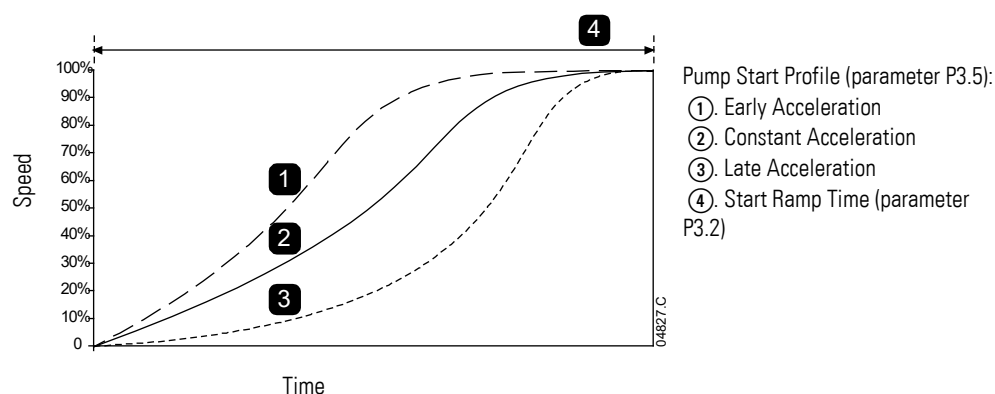

Figure 36: Pump control for starting

#### 12.7.5.1 Fine-tuning pump control

If the motor does not start or stop smoothly, adjust the pump control gain (parameter P3.12). The gain setting determines how much the soft starter will adjust future pump control starts and stops, based on information from the previous start. The gain setting affects both starting and stopping performance.

- If the motor accelerates or decelerates too quickly at the end of a start or stop, increase the gain setting by 5%~10%.
- If the motor speed fluctuates during starting or stopping, decrease the gain setting slightly.

➔ The soft starter tunes pump control to match the motor. Changing any of the following parameters will reset pump control and the first start/stop cycle will use constant current start: P2.1 Motor FLA, P20.9 Tracking Gain.

## 12.8 Stop methods

### 12.8.1 Coast to stop

Coast to stop lets the motor slow at its natural rate, with no control from the soft starter. The time required to stop will depend on the type of load.

### 12.8.2 Timed voltage ramp soft stop

Timed voltage ramp stopping reduces the voltage to the motor gradually over a defined time. This can extend the stopping time of the motor and may avoid transients on generator set supplies.

➔ The load may continue to run after the stop ramp is complete.

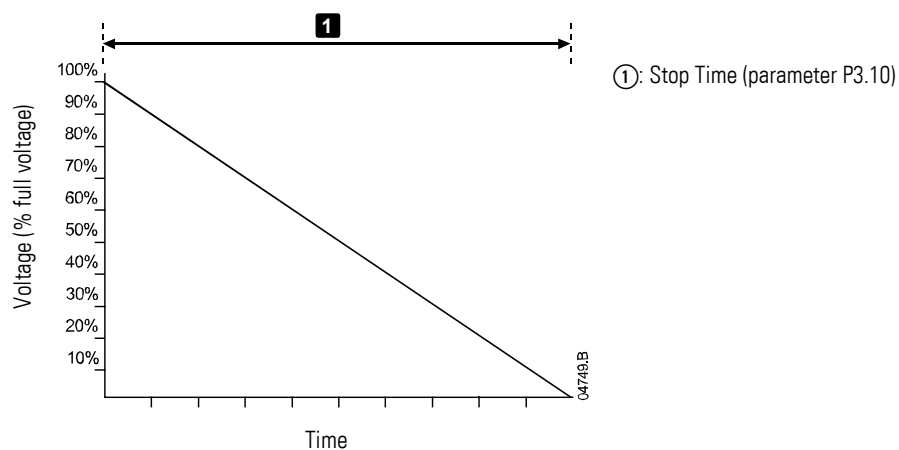

Figure 37: Timed voltage ramp soft stop

## 12 Operation

### 12.8 Stop methods

#### 12.8.3 Pump control for stopping

In a pump control soft stop, the soft starter controls the current in order to stop the motor within a specified time and using a selected deceleration profile. Pump control can be useful in extending the stopping time of low inertia loads.

If pump control is selected, the first soft stop will use timed voltage ramp. This allows the soft starter to learn the characteristics of the connected motor. This motor data is used by the soft starter during subsequent pump control stops.



Pump control does not actively slow the motor down and will not stop the motor faster than a coast to stop. To shorten the stopping time of high inertia loads, use brake.



#### CAUTION

Pump control controls the motor's speed profile, within the programmed time limit. This may result in a higher level of current than traditional control methods.

If replacing a motor connected to a soft starter programmed for pump control starting or stopping, the starter will need to learn the characteristics of the new motor. Change the value of P2.1 Motor FLA or P20.9 Tracking Gain to initiate the re-learning process. The next start will use constant current to learn the characteristics of the connected motor.

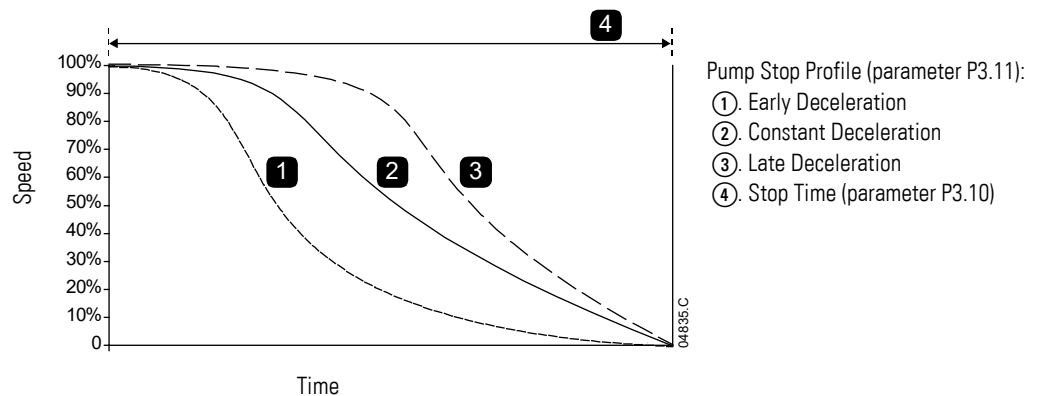

Figure 38: Pump control for stopping

Pump control is ideal for pumping applications, where it can minimise the damaging effects of fluid hammer. We recommend testing the three profiles to identify the best profile for the application.

Table 17: Pump stop profiles

<b>Pump Stop Profile</b>	<b>Application</b>
Late Deceleration	High head systems where even a small decrease in motor/pump speed results in a rapid transition between forward flow and reverse flow.
Constant Deceleration	Low to medium head, high flow applications where the fluid has high momentum.
Early Deceleration	Open pump systems where fluid must drain back through the pump without driving the pump in reverse.

## 12 Operation

### 12.8 Stop methods

#### 12.8.4 DC brake

DC brake is only recommended for applications with small moments of inertia, where the motor coasts to a stop in less than 6 minutes. For applications with large moments of inertia, soft brake is recommended.

During DC braking an increased noise level from the motor will be audible. This is a normal part of motor braking.



#### **CAUTION**

If the brake torque is set too high, or total stop time is set too long, the motor may come to a stop before the end of the brake time.

To prevent braking continuing for an extended period after the motor has stopped, and potentially causing thermal damage to the motor, a zero speed sensor must be used.



#### **CAUTION**

A high brake torque setting can result in peak currents up to motor DOL being drawn while the motor is stopping. Ensure protection fuses installed in the motor branch circuit are selected appropriately.



#### **CAUTION**

Brake operation causes the motor to heat faster than the rate calculated by the motor overload. If you are using brake, install a motor thermistor or allow sufficient restart delay (parameter P5.24).

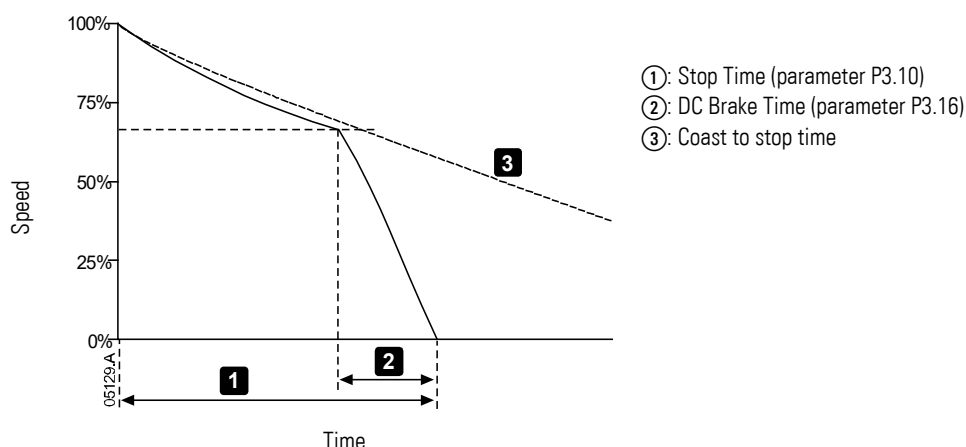

Figure 39: DC brake

Parameter settings:

- Parameter P3.9 Stop Mode: set to 'DC Brake'
- Parameter P3.10 Stop Time: This is the total braking time (1) and must be set sufficiently longer than P3.16 DC Brake Time, to allow the pre-braking stage to reduce motor speed to approximately 55%.
- Parameter P3.15 DC Brake Torque: Set as required to slow the load. If set too low, the motor will not stop completely and will coast to stop after the end of the braking period.
- Parameter P3.16 DC Brake Time: This sets the duration that DC braking is applied for (2).
- Parameter P7.1 Input 3 Function: set to 'Zero Speed Sensor'

As an example, to calculate the initial settings for P3.10 and P3.16:

- Measure the time for the motor to coast to stop, from full speed: eg 6 minutes
- Calculate 33% of the measured coast to stop time, and set as P3.10 Stop Time: 2 minutes
- Calculate 25% of the stop time (P3.10), and set as P3.16 DC Brake Time: 30 seconds

These times may need to be adjusted to achieve optimal performance.



If P3.10 Stop Time is too short, the speed will not reduce sufficiently during the pre-braking phase. Braking will not be successful and the motor will coast to stop after the stop time expires.

## 12 Operation

### 12.8 Stop methods

#### 12.8.5 Soft brake

For applications with high inertia and/or a variable load requiring the maximum possible braking torque, the soft starter can be configured for soft braking. Soft braking is always more effective than DC braking.

The starter requires an external changeover relay (K4) to control forward run and braking contactors. While braking, the soft starter reverses the phase sequence to the motor and supplies reduced current, gently slowing the load. See Soft brake diagram on page 101.

When motor speed approaches zero, the zero speed sensor (A2) stops the soft starter and opens the braking contactor (K3).

Soft braking can be used with both the primary and secondary motor sets, and must be configured separately for each.

Parameter settings:

- Parameter P3.9 Stop Mode: set to 'Soft Brake'
- Parameter P3.17 Brake Current Limit: Set as required to slow the load
- Parameter P3.18 Soft Brake Delay: Sets the time the soft starter will wait after de-energising the main contactor (K1), before changing the state of the reversing (braking) contactors (K2, K3). This minimises the possibility of a phase-to-phase short if mechanically interlocked contactors are not used.
- Parameter P7.1 Input 3 Function: set to 'Zero Speed Sensor'
- Parameter P8.1 Relay 2 Function: set to 'Soft Brake Relay'



#### **CAUTION**

You must use an upstream main contactor (K1) to isolate the starter during the switching process.



We recommend using mechanically interlocked contactors (K2, K3) to prevent both contactors being closed at the same time.

## 12 Operation

### 12.8 Stop methods

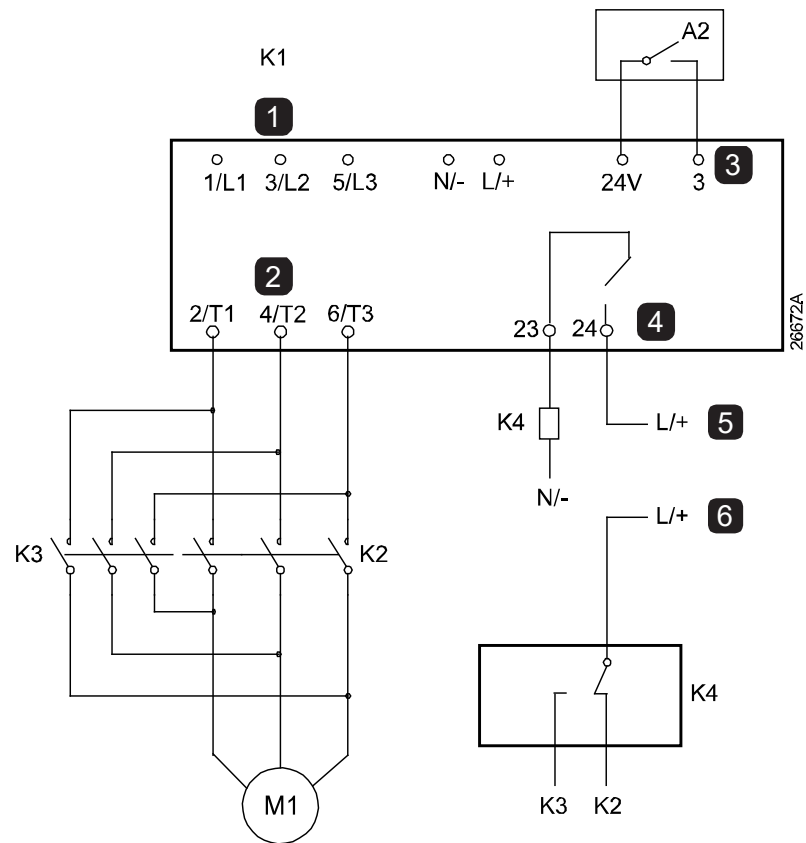

- |   |                                       |           |                   |
|---|---------------------------------------|-----------|-------------------|
| ① | Three-phase supply                    | <b>A2</b> | Zero speed sensor |
| ② | Motor terminals                       | <b>K1</b> | Main contactor    |
| ③ | Digital input 3 (= Zero Speed Sensor) | <b>K2</b> | Run contactor     |
| ④ | Relay output 2 (= Soft Brake Relay)   | <b>K3</b> | Brake contactor   |
| ⑤ | K4 coil supply                        | <b>K4</b> | Changeover relay  |
| ⑥ | K2/K3 coil supply                     |           |                   |

Figure 40: Soft brake diagram

## 12 Operation

### 12.9 Reverse direction operation

#### 12.9 Reverse direction operation

The starter can control a reversing contactor, to operate the motor in reverse direction. When reverse operation is selected, the starter will perform a soft start using the opposite phase sequence from normal operation.

Reverse operation is controlled by the Start/Stop input [1]. A programmable input must be set to reverse direction (parameters P7.1 Input 3 Function or P7.7 Input 4 Function) and an output must be set to reversing contactor (parameters P8.1 Relay 2 Function or P8.4 Relay 3 Function).

The input must be closed when the start signal is applied. The starter will keep the reverse relay in the same state until the end of the starting/stopping cycle.

This example shows a simple installation, but many different configurations are possible depending on your application requirements. Contact your local supplier for an application note showing more installation options.

→ The first start after the direction is changed will be constant current.

→ If phase sequence protection is required, install the reversing contactor on the output (motor) side of the soft starter.

12.9 Reverse direction operation

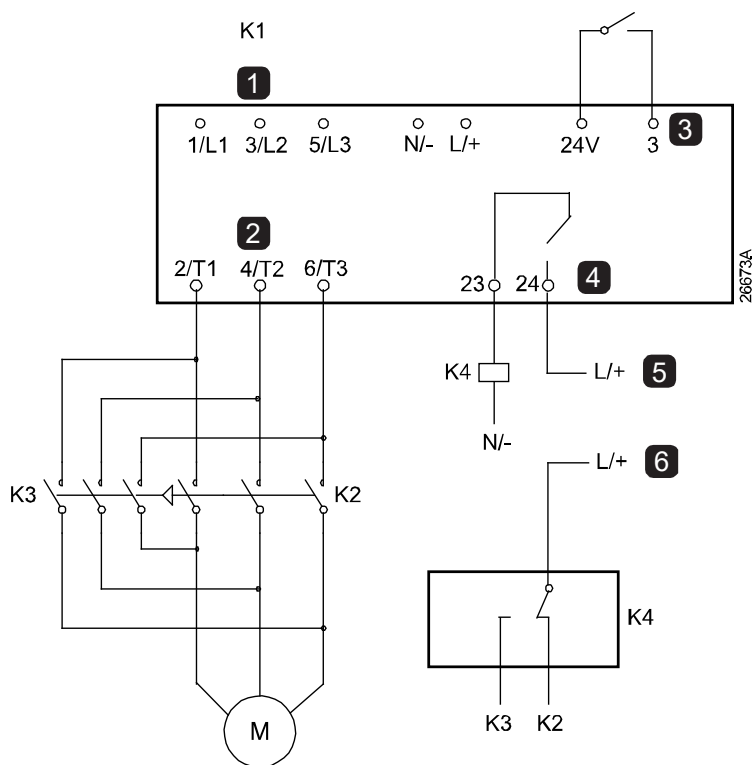

- |   |  |           |                       |
|---|--|-----------|-----------------------|
| ① | Three-phase supply                         | <b>K1</b> | Main contactor        |
| ② | Motor terminals                            | <b>K2</b> | Forward run contactor |
| ③ | Digital input 3 (set = Reverse Direction)  | <b>K3</b> | Reversing contactor   |
| ④ | Relay output 2 (set = Reversing Contactor) | <b>K4</b> | Changeover relay      |
| ⑤ | K4 coil supply                             |           |                       |
| ⑥ | K2/K3 coil supply                          |           |                       |

Figure 41: Reverse direction operation diagram

## 12 Operation

### 12.10 Jog operation

#### 12.10 Jog operation

The motor can be jogged in either forward or reverse direction to assist servicing.

Jog is available when the starter is controlled via the digital inputs or Fieldbus (parameter P1.4 Command Source = 'Terminal', 'On-board Modbus RTU', or 'Communication Card').

To use the digital inputs, you must set a programmable input to 'Jog Forward' or 'Jog Reverse' (see parameter P7.1 Input 3 Function or P7.7 Input 4 Function).

The Start/Stop input must be open. When the active jog input is closed, the motor will start jogging.

To cancel Jog operation, either open the active jog input, or use the Enable/Reset input to make the starter Not Ready.

→ To allow the starter to enter Ready state so that it can accept a jog command, the Enable/Reset input must be in the state set by parameter P7.13 Enable/Reset Logic.

→ While the starter is in Jog state, the Start/Stop input has no effect.

To use on-board Modbus RTU, see Appendix on page 154.

To use a communication card, see MN039004EN S711 Ssoft Starter - Communication Manual.

During jog, an increased noise level from the motor will be audible. This is a normal part of motor jog.



#### **CAUTION**

Slow speed running is not intended for continuous operation due to reduced motor cooling.

Jog operation causes the motor to heat faster than the rate calculated by the motor overload. If you are using jog, install a motor thermistor or allow sufficient restart delay (parameter P5.24).

12.10 Jog operation

The maximum available torque for jog forward is approximately 50%~75% of motor full load torque (FLT) depending on the motor. The torque when the motor is jogged in reverse is approximately 25%~50% of FLT.

Parameters P3.8 Jog Torque and P4.10 Jog Torque-2 control how much of the maximum available torque the soft starter will apply to the motor.

➔ Torque settings above 50% may cause increased shaft vibration.

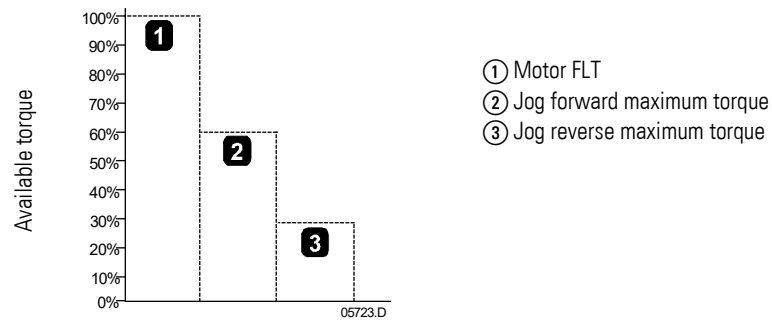

Figure 42: Jog operation

## 12 Operation

### 12.11 Inside delta operation

#### 12.11 Inside delta operation

When connecting in inside delta, first set P2.5 Motor Connection to 'Inside Delta', then enter the motor full load amperage (FLA) for P2.1 Motor FLA and the motor nameplate power for P2.2 Motor Power.

➔ For a wiring diagram, see the figure in Inside delta installation, internally bypassed on page 61.

With inside delta (six-wire) connection, you can use a starter with a lower rating, which reduces cost. However, Pump Control, Jog, Brake and Two-phase Control functions are not supported with inside delta operation. If these functions are programmed when the starter is connected inside delta, the behaviour is as given below:

Table 18: Inside delta behaviour

Unsupported option	Replacement behaviour
Pump control start	The starter performs a constant current start.
Pump control stop	If P3.10 Stop Time is set >0 seconds, the starter performs a voltage ramp stop. If P3.10 is set to 0 seconds the starter performs a coast to stop.
Jog	The starter issues a warning with the error message 'Unsupported Option'.
DC brake	The starter performs a coast to stop.
Soft brake	The starter performs a coast to stop.
Two-phase Control	The starter activates with the fault message 'Lx-Tx Shorted'.

➔ If a keypad with FLA configured for inside delta connection is installed on a starter configured for in-line connection, the FLA may exceed the in-line starter's rating. The fault message 'FLA Too High' will be displayed.

## 12.12 Secondary motor set

The soft starter can be programmed with two separate starting and stopping profiles. This allows the soft starter to control the motor in two different starting and stopping configurations.

The secondary motor set is ideal for dual winding (Dahlander) motors, multi-motor applications, or situations where the motor may start in two different conditions (such as loaded and unloaded conveyors).

The secondary motor set can also be used for duty/standby applications.

➔ For duty/standby applications, set parameter P5.31 Motor Overload to 'Log Only' and install temperature protection for each motor.

To use the secondary motor set, a programmable input must be set to 'Second Motor Select' and the input must be closed before a start command is given (see P7.1 Input 3 Function and P7.7 Input 4 Function). When the input is closed, the soft starter will use the motor parameters in parameter group P4 Motor Start/Stop 2, to start and stop the motor.

## 13 Programmable parameters

### 13.1 User Parameters menu

## 13 Programmable parameters

### 13.1 User Parameters menu

The 'User Parameters' menu lets you view and change programmable parameters that control how the soft starter operates.

To access this menu:

Press **➤** on the keypad, then scroll to 'User Parameters' and press **➤** again.

### 13.2 PIN number (password) protection

To unlock the menu, the default PIN 1 is '000000'.

To change the PIN settings, use P1.1 PIN Access Policy, and P20.1 to P20.4 to set the PIN access rights and PIN numbers.

On first power up, you need to select the access policy:

1. Press **➤** on the keypad, then scroll to 'User Parameters' and press **➤** again.
2. Press **➤** six times, to enter PIN '000000'.
3. On P1 User Configuration, press **➤**, then press **➤** on P1.1 PIN Access Policy.
4. Use the **▲** and **▼** buttons to select the access policy, then press **➤** to store. The options are:
  - No PIN required
  - Tools Locked
  - Parameters Locked
  - Both Locked
  - Select PIN Configuration (default)

See P1.1 PIN Access Policy for details.



You can access the 'Tools' menu after configuring P1.1 PIN Access Policy.

If PIN protection is already active, 'Tools' access requires configuration using P20.1 to P20.4.



#### CAUTION

It is optional to use the PIN number protection cybersecurity feature.

However, we strongly advise against disabling the PIN number as it will greatly increase vulnerability of the starter to cyber attack.

### 13.3 Altering parameter values

To change a parameter value:

- scroll to the appropriate parameter in the 'User Parameters' menu and press **>** to enter edit mode.
- to alter the parameter setting, use the **^** and **v** buttons. Pressing **^** or **v** once will increase or decrease the value by one unit. If the button is held down, the value will increase or decrease at a faster rate.
- to save changes, press **>**. The setting shown on the screen will be saved and the keypad will return to the parameter list.
- to cancel changes, press **<**. The keypad will ask for confirmation, then return to the parameter list without saving changes.

### 13.4 Locking parameters

You can prevent users from altering parameter settings by turning on the keypad parameter lock (parameter P9.8 Keypad Parameter Lock).

If a user attempts to change a parameter value when the parameter lock is active, an error message is displayed:

Access Denied Parameter Lock is On
---------------------------------------

You can also prevent users from altering parameter values by setting P1.1 PIN Access Policy to 'Parameters Locked'.

## 13 Programmable parameters

### 13.5 Parameter list versions

#### 13.5 Parameter list versions

When swapping a keypad between starters (eg to copy parameter settings, or as a replacement), the parameter versions and values on the keypad are compared with those on the starter.

The following messages are displayed if the versions and values do not match.

If the parameter list versions match, but the stored parameter values do not match:

```
Transfer Parameters
Starter to Keypad
Keypad to Starter
```

If the parameter list versions match, but the stored parameter values are significantly out of range (eg the keypad has a higher FLA than the starter):

```
FLA Too High
```

or

```
Invalid Param Value
```

If the major parameter list versions are different, or a firmware update is interrupted (eg power loss or phone disconnected), or there is a communication incompatibility:

```
Firmware Update
Required
Use Phone App
```

## 13.6 Parameter list



The table lists the text displayed on the soft starter keypad. Where the starter text is abbreviated, refer to Acronyms and abbreviations on page 12.

Table 19: Parameter list

	<b>Parameter Group</b>	<b>Default Setting</b>
<b>1</b>	<b>User Configuration</b>	
P1.1	PIN Access Policy	Select PIN Configuration
P1.2	BLE Access Policy	Select BLE Configuration
P1.3	Language	English
P1.4	Command Source	Keypad
<b>2</b>	<b>Motor Details</b>	
P2.1	Motor FLA	2 A
P2.2	Motor Power	1 kW
P2.3	Trip Class	10
P2.4	Motor Service Factor	105%
P2.5	Motor Connection	In-line
P2.6	Efficiency Class	IE4
<b>3</b>	<b>Motor Start/Stop 1</b>	
P3.1	Start Mode	Constant Current
P3.2	Start Ramp Time	00:10 (mm:ss)
P3.3	Initial Current	200%
P3.4	Current Limit	350%
P3.5	Pump Start Profile	Constant Acceleration
P3.6	Kickstart Time	000 ms
P3.7	Kickstart Level	500%
P3.8	Jog Torque	50%
P3.9	Stop Mode	Coast to Stop
P3.10	Stop Time	00:10 (mm:ss)
P3.11	Pump Stop Profile	Constant Deceleration
P3.12	Pump Control Gain	75%
P3.13	Multi Pump	Single Pump
P3.14	Start Delay	00:00 (mm:ss)
P3.15	DC Brake Torque	20%
P3.16	DC Brake Time	001 ms
P3.17	Brake Current Limit	250%
P3.18	Soft Brake Delay	400 ms
<b>4</b>	<b>Motor Start/Stop 2</b>	
P4.1	Motor FLA-2	2 A
P4.2	Motor Power-2	1 kW
P4.3	Start Mode-2	Constant Current
P4.4	Start Ramp Time-2	00:10 (mm:ss)
P4.5	Initial Current-2	200%
P4.6	Current Limit-2	350%
P4.7	Pump Start Profile-2	Constant Acceleration
P4.8	Kickstart Time-2	000 ms

## 13 Programmable parameters

### 13.6 Parameter list

	<b>Parameter Group</b>	<b>Default Setting</b>
P4.9	Kickstart Level-2	500%
P4.10	Jog Torque-2	50%
P4.11	Stop Mode-2	Coast To Stop
P4.12	Stop Time-2	00:10 (mm:ss)
P4.13	Pump Stop Profile-2	Constant Deceleration
P4.14	Pump Control Gain-2	75%
P4.15	Multi Pump-2	Single Pump
P4.16	Start Delay-2	00:00 (mm:ss)
P4.17	DC Brake Torque-2	20%
P4.18	DC Brake Time-2	001 ms
P4.19	Brake Curr Limit-2	250%
P4.20	Soft Brake Delay-2	400 ms
<b>5</b>	<b>Motor Protections</b>	
P5.1	Current Imbalance	30%
P5.2	Current Imbal Delay	00:03 (mm:ss)
P5.3	Current Imbal Action	Stop & Fault
P5.4	Undercurrent	20%
P5.5	Undercurrent Delay	00:05 (mm:ss)
P5.6	Undercurrent Action	Stop & Fault
P5.7	Overcurrent	400%
P5.8	Overcurrent Delay	00:00 (mm:ss)
P5.9	Overcurrent Action	Stop & Fault
P5.10	Undervoltage	350 V
P5.11	Undervoltage Delay	00:01 (mm:ss)
P5.12	Undervoltage Action	Stop & Fault
P5.13	Overvoltage	500 V
P5.14	Overvolt Delay	00:01 (mm:ss)
P5.15	Overvoltage Action	Stop & Fault
P5.16	Underpower	10%
P5.17	Underpower Delay	00:05 (mm:ss)
P5.18	Underpower Action	Stop & Fault
P5.19	Overpower	150%
P5.20	Overpower Delay	00:05 (mm:ss)
P5.21	Overpower Action	Stop & Fault
P5.22	Excess Start Time	00:20 (mm:ss)
P5.23	Ex. Start Time Action	Stop & Fault
P5.24	Restart Delay	00:10 (mm:ss)
P5.25	Starts Per Hour	4
P5.26	Phase Sequence	Any Sequence
P5.27	Maximum Frequency	55 Hz
P5.28	Minimum Frequency	45 Hz
P5.29	Frequency Delay	00:01 (mm:ss)
P5.30	Frequency Action	Stop & Fault
P5.31	Motor Overload	Stop & Fault
<b>6</b>	<b>Starter Protections</b>	
P6.1	Auto Reset Count	1
P6.2	Auto Reset Delay	00:05 (mm:ss)
P6.3	Fieldbus Fault Action	Stop & Fault
P6.4	Motor Therm Circuit	Stop & Fault
P6.5	Shorted SCR Action	Fault

## 13 Programmable parameters

### 13.6 Parameter list

	Parameter Group	Default Setting
<b>7</b>	<b>Digital Inputs</b>	
P7.1	Input 3 Function	Cmd Override: Terminal
P7.2	Input 3 Fault	Motor Energized
P7.3	Input 3 Fault Action	Stop & Fault
P7.4	Input 3 Fault Delay	00:00 (mm:ss)
P7.5	Input 3 Initial Delay	00:00 (mm:ss)
P7.6	Input 3 Fault Name	External Fault Input 3
P7.7	Input 4 Function	External Fault NO
P7.8	Input 4 Fault	Motor Energized
P7.9	Input 4 Fault Action	Stop & Fault
P7.10	Input 4 Fault Delay	00:00 (mm:ss)
P7.11	Input 4 Initial Delay	00:00 (mm:ss)
P7.12	Input 4 Fault Name	External Fault Input 4
P7.13	Enable/Reset Logic	Normally Closed NC
<b>8</b>	<b>Relay Outputs</b>	
P8.1	Relay 2 Function	Bypassed
P8.2	Relay 2 On Delay	00:00 (mm:ss)
P8.3	Relay 2 Off Delay	00:00 (mm:ss)
P8.4	Relay 3 Function	Fault
P8.5	Relay 3 On Delay	00:00 (mm:ss)
P8.6	Relay 3 Off Delay	00:00 (mm:ss)
P8.7	Low Current Flag	50%
P8.8	High Current Flag	100%
P8.9	Motor Overload Flag	80%
<b>9</b>	<b>Display</b>	
P9.1	Default Screen	Last Used
P9.2	Screen Timeout	1 minute
P9.3	Measurement Units	IEC (kW/°C)
P9.4	Graph Data	Current
P9.5	Graph Timebase	30 seconds
P9.6	Graph Max Adjustment	400%
P9.7	Graph Min Adjustment	0%
P9.8	Keypad Param Lock	Read & Write
P9.9	User Monitor 1	Current
P9.10	User Monitor 2	Voltage
P9.11	User Monitor 3	Mains Frequency
P9.12	User Monitor 4	Motor pf
P9.13	User Monitor 5	Motor Power
P9.14	User Monitor 6	Motor Overload (%)
<b>P10</b>	<b>Fieldbus</b>	
P10.1	Modbus RTU Address	1
P10.2	Modbus RTU Baud	19200
P10.3	Modbus RTU Parity	Even
P10.4	Modbus RTU Timeout	Off
P10.5	IP Address	192.168.001.011
P10.6	Gateway Address	192.168.001.001
P10.7	Subnet Mask	255.255.255.000
P10.8	Fieldbus Select	Modbus RTU
P10.9	Ext Network Timeout	Off

## 13 Programmable parameters

### 13.6 Parameter list

	<b>Parameter Group</b>	<b>Default Setting</b>
<b>P20</b>	<b>Advanced</b>	
P20.1	PIN 1 Access Rights	Unlock Parameters
P20.2	Set PIN 1	000000
P20.3	PIN 2 Access Rights	PIN 2 Disabled
P20.4	Set PIN 2	000000
P20.5	Main Contactor Time	400 ms
P20.6	Shunt Trip Mode	Disable
P20.7	Remote LED Mode	Terminal Control
P20.8	Current Calibration	100%
P20.9	Tracking Gain	50%
P20.10	Pedestal Detect	80%
P20.11	Fire Mode Enable	Disable
P20.12	Model Rating	MR NOT SET
P20.13	CT PCB Revision	0
P20.14	Gate PCB Revision	0
P20.15	Backplane PCB Rev	0

## 13.7 P1 User Configuration

### P1.1 – PIN Access Policy

<b>Options:</b>	No PIN required	No PIN required. Users can access all menus.
	Tools Locked	Select this option to lock the 'Tools' menu. The user will need to enter a PIN to access this menu.
	Parameters Locked	Select this option to lock the 'User Parameters'. The user will be able to access this menu and view the settings but they will need to enter a PIN to edit the parameters. If you select this option, the following menu will also be locked: Quick Setup and Load/Save Settings.
	Both Locked	Select this option to lock the 'User Parameters' and 'Tools' menus. The user will need to enter a PIN to edit the parameters and access the 'Tools' menu.
	Select PIN Configuration (default)	This is the default setting. You must select another option when a new unit is powered up for the first time.

**Description:** Sets the access policy for the starter. You can select which portions of the menus will be locked.

### P1.2 – BLE Access Policy

<b>Options:</b>	BLE Not Allowed	Bluetooth access is not allowed.
	BLE Secure Pairing	Select this option to enable Bluetooth pairing using a one-time random passkey code.
	BLE Auto Pairing	Select this option to enable Bluetooth pairing without requiring a passkey code.
	Select BLE Configuration (default)	This is the default setting. You must select another option when a new unit is powered up for the first time.

**Description:** Sets the Bluetooth access policy for the starter. You can select whether BLE access is disabled or not. See Cybersecurity on page 82 for more information.

### P1.3 – Language

<b>Options:</b>	English (default)	Português
	Deutsch	Italiano
	Español	Chinese
	Français	Russian

**Description:** Selects which language the keypad will use to display messages and feedback.

## 13 Programmable parameters

### 13.7 P1 User Configuration

#### P1.4 – Command Source

<b>Options:</b>	Keypad (default)	The S711 will accept start and stop commands from the keypad.
	Terminal	The S711 will accept start and stop commands only from the digital inputs.
	On-board Modbus RTU	The S711 will accept start and stop commands only from on-board Modbus RTU.
	Communication Card	The S711 will accept start and stop commands only from the communication card.

**Description:** Selects the command source for controlling the soft starter.



The starter will accept the following commands, independent of the command source:

- Stop and reset commands from the keypad
- Reset commands from the digital inputs.

## 13.8 P2 Motor Details

### P2.1 – Motor FLA

<b>Range:</b>	2 A - Starter nominal current	<b>Default:</b>	2
<b>Description:</b>	Matches the starter to the connected motor's full load amperage. Set to the full load amperage (FLA) rating shown on the motor nameplate.		

### P2.2 – Motor Power

<b>Range:</b>	1 - 500 kW or 670 HP	<b>Default:</b>	1
<b>Description:</b>	Sets the running power of the connected motor, in kilowatts or horsepower, depending on the setting of P9.3 Measurement Units. This setting is the basis for power reporting and protection.		



The motor nameplate may state different power ratings for different supply voltages or power connections. Ensure that the motor power setting is accurate for the installation.

### P2.3 – Trip Class

<b>Options:</b>	5 - 30	<b>Default:</b>	10
<b>Description:</b>	Selects the trip class.		

### P2.4 – Motor Service Factor

<b>Range:</b>	100% - 130%	<b>Default:</b>	105%
<b>Description:</b>	Set according to the motor datasheet. If the service factor of the motor is not known, set it to 100%. <ul style="list-style-type: none"> <li>For IEC motor applications, motor service factor should be set to 100%.</li> </ul> See also Motor overload protection on page 45.		



Check the requirements from the applicable local electrical code. The NEC (National Electrical Code) does not allow the service factor to be set above 1.40. NEC, article 430 Part C, allows for different overload multiplier factors depending on the motor and operating conditions. NEC section 430-32 outlines the allowable service factor for different motors.

## 13 Programmable parameters

### 13.8 P2 Motor Details

#### P2.5 – Motor Connection

<b>Options:</b>	In-line (default)
	Inside Delta

**Description:** This setting must match how the motor and starter three-phase wiring has been connected.

➔ With inside delta connection, you can use a starter with a lower rating, which reduces cost. However, Pump Control, Jog, Brake and Two-phase Control functions are not supported with inside delta.

#### P2.6 – Efficiency Class

<b>Options:</b>	IE3
	IE4 (default)

**Description:** Selecting the correct motor type (IE3 or IE4) will allow for the relevant electrical characteristics of the motor and help manage the inrush current at the beginning of a start ramp.

➔ For IE2 and IE1 motors, and submersible bore pumps, select 'IE3'.

➔ Selecting 'IE4' for an IE3, IE2 or IE1 motor may result in poor starts, mis-timed SCR firing, current spikes/torque transients, and nuisance tripping.

Selecting 'IE3' for an IE4 motor may result in a current transient approximately double the set FLA, at the beginning of a start.

## 13.9 P3 Motor Start/Stop 1

### P3.1 – Start Mode

<b>Options:</b>	Constant Current (default)
	Pump Control

**Description:** Selects the soft start mode.



The soft starter will apply the current limit on all soft starts, including pump control. If the current limit is too low or the start ramp time is too short, the motor may not start successfully.

### P3.2 – Start Ramp Time

**Range:** 0:01 - 3:00 (minutes:seconds) **Default:** 10 seconds

**Description:** Sets the total start time for a pump control start or the ramp time for current ramp starting (from the initial current to the current limit).

### P3.3 – Initial Current

**Range:** 100% - 600% FLA **Default:** 200%

**Description:** Sets the initial start current level for current ramp starting, as a percentage of motor full load amperage. Set so that the motor begins to accelerate immediately after a start is initiated.  
If current ramp starting is not required, set the initial current equal to the current limit.

### P3.4 – Current Limit

**Range:** 100% - 600% FLA **Default:** 350%

**Description:** Sets the current limit for constant current and current ramp soft starting, as a percentage of motor full load amperage.

### P3.5 – Pump Start Profile

<b>Options:</b>	Early Acceleration	Late Acceleration
	Constant Acceleration (default)	

**Description:** Selects which profile the soft starter will use for a pump control soft start.



The starter will apply the current limit on all soft starts, including pump control. If the current limit is too low or the start ramp time is too short, the motor may not start successfully.

### P3.6 – Kickstart Time

**Range:** 0 - 2000 milliseconds **Default:** 0000 ms

**Description:** Sets the kickstart duration. A setting of 0 disables kickstart.

## 13 Programmable parameters

### 13.9 P3 Motor Start/Stop 1

#### P3.7 – Kickstart Level

<b>Range:</b>	100% - 600% FLA	<b>Default:</b>	500%
<b>Description:</b>	Sets the level of the kickstart current.		



**CAUTION** Kickstart subjects the mechanical equipment to increased torque levels. Ensure the motor, load and couplings can handle the additional torque before using this feature.

#### P3.8 – Jog Torque

<b>Range:</b>	20% - 100%	<b>Default:</b>	50%
<b>Description:</b>	Sets the current limit for jog operation. The soft starter can jog the motor at a reduced speed, which allows precise positioning of belts and flywheels. Jog can be used for either forward or reverse operation.		

#### P3.9 – Stop Mode

<b>Options:</b>	Coast To Stop (default)	DC Brake
	Voltage Ramp	Soft Brake
	Pump Control	

**Description:** Selects the stop mode.

#### P3.10 – Stop Time

<b>Range:</b>	0:00 - 4:00 (minutes:seconds)	<b>Default:</b>	10 seconds
<b>Description:</b>	Sets the time for soft stopping the motor using timed voltage ramp or pump control. If a main contactor is installed, the contactor must remain closed until the end of the stop time. Use the main contactor output [13, 14] to control the main contactor.		

#### P3.11 – Pump Stop Profile

<b>Options:</b>	Early Deceleration
	Constant Deceleration (default)
	Late Deceleration

**Description:** Selects which profile the soft starter will use for a pump control soft stop.

#### P3.12 – Pump Control Gain

<b>Range:</b>	1% - 200%	<b>Default:</b>	75%
<b>Description:</b>	Adjusts the performance of pump control. This setting affects both starting and stopping control.		

#### P3.13 – Multi Pump

<b>Options:</b>	Single Pump (default)
	Manifold Pump

**Description:** Disables the pump control learning function when stopping, if the pump being controlled is one of several discharging into a common manifold.

## 13 Programmable parameters

### 13.9 P3 Motor Start/Stop 1

#### P3.14 – Start Delay

---

**Range:** 0:00 - 60:00 (minutes:seconds) **Default:** 0 second

**Description:** Sets a delay after the starter receives a start command, before it starts the motor.

#### P3.15 – DC Brake Torque

---

**Range:** 20% - 100% **Default:** 20%

**Description:** Sets the amount of brake torque the soft starter will use to slow the motor.

#### P3.16 – DC Brake Time

---

**Range:** 1 - 30 seconds **Default:** 1 second

**Description:** Sets the duration that DC braking is applied for.



You should set one of the programmable inputs (P7.1 Input 3 Function or P7.7 Input 4 Function) to 'Zero Speed Sensor'. If the motor physically stops before the brake time is complete, the motor will be damaged.

#### P3.17 – Brake Current Limit

---

**Range:** 100% - 600% FLA **Default:** 250%

**Description:** Sets the current limit for soft brake.

#### P3.18 – Soft Brake Delay

---

**Range:** 400 - 2000 milliseconds **Default:** 400 ms

**Description:** Sets the time the soft starter will wait after de-energising the main contactor (K1), before changing the state of the reversing (braking) contactors (K2, K3). This minimises the possibility of a phase-to-phase short if mechanically interlocked contactors are not used.

## 13 Programmable parameters

### 13.10 P4 Motor Start/Stop 2

#### 13.10 P4 Motor Start/Stop 2

The parameters in this group control the operation of the secondary configuration of the motor. Use the programmable input to select the active motor set.

See Secondary motor set on page 106 for details.

##### P4.1 – Motor FLA-2

<b>Range:</b>	2 A - Starter nominal current	<b>Default:</b>	2
<b>Description:</b>	Sets the secondary motor's full load amperage.		

##### P4.2 – Motor Power-2

<b>Range:</b>	1 - 500 kW or 670 HP	<b>Default:</b>	1
<b>Description:</b>	Sets the running power of the secondary motor, in kilowatts or horsepower, depending on the setting of P9.3 Measurement Units.		

##### P4.3 – Start Mode-2

<b>Options:</b>	Constant Current (default)
	Pump Control
<b>Description:</b>	Selects the soft start mode.

##### P4.4 – Start Ramp Time-2

<b>Range:</b>	0:01 - 3:00 (minutes:seconds)	<b>Default:</b>	10 seconds
<b>Description:</b>	Sets the total start time for a pump control start or the ramp time for current ramp starting (from the initial current to the current limit).		

##### P4.5 – Initial Current-2

<b>Range:</b>	100% - 600% FLA	<b>Default:</b>	200%
<b>Description:</b>	Sets the initial start current level for current ramp starting, as a percentage of motor full load amperage. Set so that the motor begins to accelerate immediately after a start is initiated. If current ramp starting is not required, set the initial current equal to the current limit.		

##### P4.6 – Current Limit-2

<b>Range:</b>	100% - 600% FLA	<b>Default:</b>	350%
<b>Description:</b>	Sets the current limit for constant current and current ramp soft starting, as a percentage of motor full load amperage.		



The soft starter will apply the current limit on all soft starts, including pump control. If the current limit is too low or the start ramp time is too short, the motor may not start successfully.

## 13 Programmable parameters

### 13.10 P4 Motor Start/Stop 2

#### P4.7 – Pump Start Profile-2

<b>Options:</b>	Early Acceleration
	Constant Acceleration (default)
	Late Acceleration

**Description:** Selects which profile the soft starter will use for a pump control soft start.

#### P4.8 – Kickstart Time-2

**Range:** 0 - 2000 milliseconds **Default:** 0000 ms

**Description:** Sets the kickstart duration. A setting of 0 disables kickstart.

#### P4.9 – Kickstart Level-2

**Range:** 100% - 600% FLA **Default:** 500%

**Description:** Sets the level of the kickstart current.

#### P4.10 – Jog Torque-2

**Range:** 20% - 100% **Default:** 50%

**Description:** Sets the current limit for jog operation.

#### P4.11 – Stop Mode-2

<b>Options:</b>	Coast To Stop (default)	DC Brake
	Voltage Ramp	Soft Brake
	Pump Control	

**Description:** Selects the stop mode.

#### P4.12 – Stop Time-2

**Range:** 0:00 - 4:00 (minutes:seconds) **Default:** 10 seconds

**Description:** Sets the time for soft stopping the motor using timed voltage ramp or pump control. If a main contactor is installed, the contactor must remain closed until the end of the stop time. Use the main contactor output [13, 14] to control the main contactor.

#### P4.13 – Pump Stop Profile-2

<b>Options:</b>	Early Deceleration
	Constant Deceleration (default)
	Late Deceleration

**Description:** Selects which profile the soft starter will use for a pump control soft stop.

#### P4.14 – Pump Control Gain-2

**Range:** 1% - 200% **Default:** 75%

**Description:** Adjusts the performance of pump control. This setting affects both starting and stopping control.

#### P4.15 – Multi Pump-2

<b>Options:</b>	Single Pump (default)
	Manifold Pump

**Description:** Disables the pump control learning function when stopping, if the pump being controlled is one of several discharging into a common manifold.

## 13 Programmable parameters

### 13.10 P4 Motor Start/Stop 2

#### P4.16 – Start Delay-2

---

**Range:** 0:00 - 60:00 (minutes:seconds) **Default:** 0 second

**Description:** Sets a delay after the starter receives a start command, before it starts the motor.

#### P4.17 – DC Brake Torque-2

---

**Range:** 20% - 100% **Default:** 20%

**Description:** Sets the amount of brake torque the soft starter will use to slow the motor.

#### P4.18 – DC Brake Time-2

---

**Range:** 0:01 - 0:30 (minutes:seconds) **Default:** 1 second

**Description:** Sets the duration that DC braking is applied for.



You should set one of the programmable inputs (P7.1 Input 3 Function or P7.7 Input 4 Function) to 'Zero Speed Sensor'. If the motor physically stops before the brake time is complete, the motor will be damaged.

#### P4.19 – Brake Current Limit-2

---

**Range:** 100% - 600% FLA **Default:** 250%

**Description:** Sets the current limit for soft brake.

#### P4.20 – Soft Brake Delay-2

---

**Range:** 400 - 2000 milliseconds **Default:** 400 ms

**Description:** Sets the time the soft starter will wait after a stop signal is received, before it begins to supply braking current to the motor. Set to allow time for the main contactor and the line contactor to switch.

### 13.11 P5 Motor Protections

P5.1 – Current Imbalance

<b>Range:</b>	10% - 50%	<b>Default:</b>	30%
<b>Description:</b>	Sets the trip point for current imbalance protection.		

P5.2 – Current Imbalance Delay

<b>Range:</b>	0:01 - 4:00 (minutes:seconds)	<b>Default:</b>	3 seconds
<b>Description:</b>	Slows the soft starter's response to current imbalance, avoiding trips due to momentary fluctuations.		

P5.3 – Current Imbalance Action

<b>Options:</b>	Stop & Fault (default)	The soft starter will stop the motor as selected in parameter P3.9 Stop Mode or P4.11 Stop Mode-2, then enter fault state. The fault must be reset before the starter can restart.
	Fault Auto Reset	The soft starter will stop the motor as selected in parameter P3.9 Stop Mode or P4.11 Stop Mode-2, then enter fault state. The fault will reset after the auto reset delay.
	Fault Coast	The soft starter will remove power and the motor will coast to stop. The fault must be reset before the starter can restart.
	Warning	The protection will be written to the event log and the screen will show a warning message, but the soft starter will continue to operate.
	Log Only	The protection will be written to the event log but the soft starter will continue to operate.
	Fault + Shunt Relay	The soft starter will remove power and the motor will coast to stop. The shunt trip relay [13, 14] will activate and the circuit breaker will disconnect the three-phase motor supply from the soft starter. The circuit breaker must be manually reset before operation can resume. This option is only effective if parameter P20.6 Shunt Trip Mode is set to 'Enable'.

**Description:** Selects the soft starter's response to each protection. All protection events are written to the event log.

P5.4 – Undercurrent

<b>Range:</b>	0% - 100%	<b>Default:</b>	20%
<b>Description:</b>	Sets the trip point for undercurrent protection, as a percentage of motor full load amperage. Set to a level between the motor's normal working range and the motor's magnetising (no load) current (typically 25% to 35% of full load amperage). A setting of 0% disables undercurrent protection.		

P5.5 – Undercurrent Delay

<b>Range:</b>	0:01 - 4:00 (minutes:seconds)	<b>Default:</b>	5 seconds
<b>Description:</b>	Slows the soft starter's response to undercurrent, avoiding trips due to momentary fluctuations.		

## 13 Programmable parameters

### 13.11 P5 Motor Protections

#### P5.6 – Undercurrent Action

<b>Options:</b>	Stop & Fault (default)	Warning
	Fault Auto Reset	Log Only
	Fault Coast	Fault + Shunt Relay

**Description:** Selects the soft starter's response to the protection event.

#### P5.7 – Overcurrent

**Range:** 80% - 600% **Default:** 400%

**Description:** Sets the trip point for overcurrent protection, as a percentage of motor full load amperage.

#### P5.8 – Overcurrent Delay

**Range:** 0:01 - 1:00 (minutes:seconds) **Default:** 0 second

**Description:** Slows the soft starter's response to overcurrent, avoiding trips due to momentary overcurrent events.

#### P5.9 – Overcurrent Action

<b>Options:</b>	Stop & Fault (default)	Warning
	Fault Auto Reset	Log Only
	Fault Coast	Fault + Shunt Relay

**Description:** Selects the soft starter's response to the protection event.

#### P5.10 – Undervoltage

**Range:** 100 - 1200 V **Default:** 350

**Description:** Sets the trip point for undervoltage protection.



Voltage protections will not operate correctly until the starter is in Run mode.

#### P5.11 – Undervoltage Delay

**Range:** 0:01 - 1:00 (minutes:seconds) **Default:** 1 second

**Description:** Slows the soft starter's response to undervoltage, avoiding trips due to momentary fluctuations.

#### P5.12 – Undervoltage Action

<b>Options:</b>	Stop & Fault (default)	Warning
	Fault Auto Reset	Log Only
	Fault Coast	Fault + Shunt Relay

**Description:** Selects the soft starter's response to the protection event.

#### P5.13 – Overvoltage

**Range:** 100 - 1500 V **Default:** 500

**Description:** Sets the trip point for overvoltage protection.

## 13 Programmable parameters

### 13.11 P5 Motor Protections

#### P5.14 – Overvoltage Delay

<b>Range:</b>	0:01 - 1:00 (minutes:seconds)	<b>Default:</b>	1 second
<b>Description:</b>	Slows the soft starter's response to overvoltage, avoiding trips due to momentary fluctuations.		

#### P5.15 – Overvoltage Action

<b>Options:</b>	Stop & Fault (default)	Warning
	Fault Auto Reset	Log Only
	Fault Coast	Fault + Shunt Relay

**Description:** Selects the soft starter's response to the protection event.

#### P5.16 – Underpower

<b>Range:</b>	10% - 120%	<b>Default:</b>	10%
<b>Description:</b>	Sets the trip point for underpower protection as a percentage of the set motor nameplate power.		

#### P5.17 – Underpower Delay

<b>Range:</b>	0:01 - 1:00 (minutes:seconds)	<b>Default:</b>	5 seconds
<b>Description:</b>	Slows the soft starter's response to underpower, avoiding trips due to momentary fluctuations.		

#### P5.18 – Underpower Action

<b>Options:</b>	Stop & Fault (default)	Warning
	Fault Auto Reset	Log Only
	Fault Coast	Fault + Shunt Relay

**Description:** Selects the soft starter's response to the protection event.

#### P5.19 – Overpower

<b>Range:</b>	80% - 200%	<b>Default:</b>	150%
<b>Description:</b>	Sets the trip point for overpower protection as a percentage of the set motor nameplate power.		

#### P5.20 – Overpower Delay

<b>Range:</b>	0:01 - 1:00 (minutes:seconds)	<b>Default:</b>	5 seconds
<b>Description:</b>	Slows the soft starter's response to overpower, avoiding trips due to momentary fluctuations.		

#### P5.21 – Overpower Action

<b>Options:</b>	Stop & Fault (default)	Warning
	Fault Auto Reset	Log Only
	Fault Coast	Fault + Shunt Relay

**Description:** Selects the soft starter's response to the protection event.

## 13 Programmable parameters

### 13.11 P5 Motor Protections

#### P5.22 – Excess Start Time

**Range:** 0:01 - 4:00 (minutes:seconds) **Default:** 20 seconds

**Description:** Excess start time is the maximum time the soft starter will attempt to start the motor. If the motor does not transition to Run mode within the programmed limit, the starter will trip. Set for a period slightly longer than required for a normal healthy start.

#### P5.23 – Excess Start Time Action

<b>Options:</b>	Stop & Fault (default)	Warning
	Fault Auto Reset	Log Only
	Fault Coast	Fault + Shunt Relay

**Description:** Selects the soft starter's response to the protection event.

#### P5.24 – Restart Delay

**Range:** 00:01 - 60:00 (minutes:seconds) **Default:** 10 seconds

**Description:** The soft starter can be configured to force a delay between the end of a stop and the beginning of the next start. During the restart delay period, the screen shows the time remaining before another start can be attempted.

#### P5.25 – Starts Per Hour

**Range:** 0 - 10 **Default:** 4

**Description:** Sets the maximum number of starts the soft starter will attempt in a 60 minute period.



#### CAUTION

A setting of 0 disables this protection. It will allow an indefinite number of starts per hour and no cooling time. In this case, the thermal model will only provide motor overload protection while starting and running as cooling time is zero, and the model resets before each start.

#### P5.26 – Phase Sequence

<b>Options:</b>	Any Sequence (default)
	Positive Only
	Negative Only

**Description:** Selects which phase sequences the soft starter will allow at a start. During its pre-start checks, the starter examines the sequence of the phases at its input terminals and trips if the actual sequence does not match the selected option.

#### P5.27 – Maximum Frequency

**Range:** 35.00 - 75.00 Hz **Default:** 55

**Description:** Sets the upper limit for the supply frequency trip.

## 13 Programmable parameters

### 13.11 P5 Motor Protections

#### P5.28 – Minimum Frequency

**Range:** 35.00 - 75.00 Hz **Default:** 45

**Description:** Sets the lower limits for the supply frequency trip.

#### P5.29 – Frequency Delay

**Range:** 0:01 - 1:00 (minutes:seconds) **Default:** 1 second

**Description:** Slows the S711's response to frequency disturbances, avoiding trips due to momentary fluctuations.

#### P5.30 – Frequency Action

<b>Options:</b>	Stop & Fault (default)	Warning
	Fault Auto Reset	Log Only
	Fault Coast	Fault + Shunt Relay

**Description:** Selects the soft starter's response to the protection event.

#### P5.31 – Motor Overload

<b>Options:</b>	Stop & Fault (default)	Warning
	Fault Auto Reset	Log Only
	Fault Coast	Fault + Shunt Relay

**Description:** Selects the soft starter's response to the protection event.

The soft starter's motor overload protection constantly monitors the motor current.

When an overload is detected, the starter will respond as determined by parameter P5.31 Motor Overload. The motor overload trip cannot be reset until the overload clears. The starter will be unable to attempt another start if there is insufficient overload capacity remaining.

The Reset Overload feature can be used to override a motor overload, in the event of an emergency. See Reset motor overload on page 73.

## 13 Programmable parameters

### 13.12 P6 Starter Protections

#### 13.12 P6 Starter Protections

##### P6.1 – Auto Reset Count

<b>Range:</b>	1 - 5	<b>Default:</b>	1
<b>Description:</b>	Sets how many times the soft starter will auto reset, if it continues to trip. The reset counter increases by one each time the soft starter auto resets, and resets after a successful start.		

##### P6.2 – Auto Reset Delay

<b>Range:</b>	0:05 - 15:00 (minutes:seconds)	<b>Default:</b>	5 seconds
<b>Description:</b>	Sets a delay before the soft starter will auto reset a trip.		

##### P6.3 – Fieldbus Fault Action

<b>Options:</b>	Stop & Fault (default)	The soft starter will stop the motor as selected in parameter P3.9 or P4.11 Stop Mode, then enter fault state. The fault must be reset before the starter can restart.
	Fault Auto Reset	The soft starter will stop the motor as selected in parameter P3.9 or P4.11 Stop Mode, then enter fault state. The fault will reset after the auto reset delay.
	Fault Coast	The soft starter will remove power and the motor will coast to stop. The fault must be reset before the starter can restart.
	Warning	The protection will be written to the event log and the screen will show a warning message, but the soft starter will continue to operate.
	Log Only	The protection will be written to the event log but the soft starter will continue to operate.
	Fault + Shunt Relay	The soft starter will remove power and the motor will coast to stop. The shunt trip relay [13, 14] will activate and the circuit breaker will disconnect the three-phase motor supply from the soft starter. The circuit breaker must be manually reset before operation can resume. This option is only effective if parameter P20.6 Shunt Trip Mode is set to 'Enable'.

**Description:** Selects the soft starter's response to each protection. All protection events are written to the event log.

##### P6.4 – Motor Thermistor Circuit

<b>Options:</b>	Stop & Fault (default)	Warning
	Fault Auto Reset	Log Only
	Fault Coast	Fault + Shunt Relay

**Description:** Selects the soft starter's response to the protection event.

## 13 Programmable parameters

### 13.12 P6 Starter Protections

#### P6.5 – Shorted SCR Action

<b>Options:</b>	Two-phase Control
	Fault (default)
	Fault + Shunt Relay

**Description:** Selects whether the soft starter will allow two-phase control operation, if the soft starter is damaged on one phase (this could be due to a shorted SCR or a welded bypass contactor). The soft starter will use two-phase control, allowing the motor to continue operating in critical applications. See Two-phase control on page 86 for further information.

## 13 Programmable parameters

### 13.13 P7 Digital Inputs

#### 13.13 P7 Digital Inputs

P7.1 – Input 3 Function

Options:		
Cmd Override: Modbus		Overrides the setting of P1.4 and sets the command source to on-board Modbus RTU.
Cmd Override: ComCard		Overrides the setting of P1.4 and sets the command source to the optional communication card.
Cmd Override: Terminal (default)		Overrides the setting of P1.4 and sets the command source to the digital inputs.
Cmd Override: Keypad		Overrides the setting of P1.4 and sets the command source to the keypad.
External Fault NO		A closed circuit across [3] generates a fault message in the soft starter.
External Fault NC		An open circuit across [3] generates a fault message in the soft starter.
Fire Mode		A closed circuit across [3] activates fire mode. When the soft starter receives a start command, it will continue to run until a stop command is received, ignoring most fault conditions and warnings ('Power Loss' and 'Phase Sequence' are not ignored). See also P20.11 Fire Mode Enable and Fire mode on page 87.
Jog Forward		Changes the function of the Start/Stop input to jog forward operation. This is a level-triggered input.
Jog Reverse		Changes the function of the Start/Stop input to jog reverse operation. This is a level-triggered input.
Zero Speed Sensor		An open circuit across [3] indicates to the soft starter that the motor has reached a standstill. The soft starter requires a normally open (NO) zero speed sensor.
Second Motor Select		A closed circuit across [3] instructs the starter to use the secondary motor configuration for the next start/stop cycle.
Fault Reset		When selected, the input is normally open (NO). If a fault occurs, momentarily closing the input will attempt to reset the fault. This is an edge-triggered input, the reset will only occur on the open to close transition. NOTE: P7.13 Enable/Reset Logic does not operate on programmable inputs 3 and 4. This parameter only operates in conjunction with the dedicated Enable/Reset input.
Reverse Direction		A closed circuit across [3] instructs the starter to reverse the phase sequence for the next start, via a reversing contactor.

**Description:** Selects the function of Input 3.

## 13 Programmable parameters

### 13.13 P7 Digital Inputs

#### P7.2 – Input 3 Fault

<b>Options:</b>	Always Active	An external fault can occur at any time when the soft starter is receiving power.
	Motor Energized (default)	An external fault can occur while the soft starter is running, stopping or starting.
	Bypassed	An external fault can only occur while the internal bypass contactor is closed.

**Description:** Selects when an external fault can occur.

#### P7.3 – Input 3 Fault Action

<b>Options:</b>	Stop & Fault (default)	Warning
	Fault Auto Reset	Log Only
	Fault Coast	Fault + Shunt Relay

**Description:** Selects the soft starter's response to the protection event.

#### P7.4 – Input 3 Fault Delay

**Range:** 0:00 - 4:00 (minutes:seconds) **Default:** 0 second

**Description:** Sets a delay between the input activating and the soft starter entering fault state.

#### P7.5 – Input 3 Initial Delay

**Range:** 00:00 - 30:00 (minutes:seconds) **Default:** 0 second

**Description:** Sets a delay before an external fault can occur. The initial delay is counted from the time a start command is received. The state of the input is ignored until the initial delay has elapsed. This delay does not apply when P7.2 Input 3 Fault is set to 'Always Active'.

#### P7.6 – Input 3 Fault Name

<b>Options:</b>	Custom Text Input 3
	External Fault Input 3 (default)

**Description:** Selects a message for the keypad to display when Input 3 is active.

The custom text can be uploaded via the S711 Connect app.

#### P7.7 – Input 4 Function

<b>Options:</b>	External Fault NO (default)	Zero Speed Sensor
	External Fault NC	Second Motor Select
	Fire Mode	Fault Reset
	Jog Forward	Reverse Direction
	Jog Reverse	

**Description:** Selects the function of Input 4. See parameter P7.1 Input 3 Function for details.

#### P7.8 – Input 4 Fault

<b>Options:</b>	Always Active
	Motor Energized (default)
	Bypassed

**Description:** Selects when an external fault can occur.

## 13 Programmable parameters

### 13.13 P7 Digital Inputs

#### P7.9 – Input 4 Fault Action

<b>Options:</b>	Stop & Fault (default)	Warning
	Fault Auto Reset	Log Only
	Fault Coast	Fault + Shunt Relay

**Description:** Selects the soft starter's response to the protection event.

#### P7.10 – Input 4 Fault Delay

**Range:** 0:00 - 4:00 (minutes:seconds) **Default:** 0 second

**Description:** Sets a delay between the input activating and the soft starter entering fault state.

#### P7.11 – Input 4 Initial Delay

**Range:** 00:00 - 30:00 (minutes:seconds) **Default:** 0 second

**Description:** Sets a delay before an external fault can occur. The initial delay is counted from the time a start command is received. The state of the input is ignored until the initial delay has elapsed. This delay does not apply when P7.8 Input 4 Fault is set to 'Always Active'.

#### P7.12 – Input 4 Fault Name

<b>Options:</b>	Custom Text Input 4
	External Fault Input 4 (default)

**Description:** Selects a message for the keypad to display when Input 4 is active.  
The custom text can be uploaded via the S711 Connect app.

#### P7.13 – Enable/Reset Logic

<b>Options:</b>	Normally Open NO
	Normally Closed NC (default)

**Description:** Selects whether the Enable/Reset input [2] is normally open or normally closed.



If the Enable/Reset input is activated, the starter will not operate.

### 13.14 P8 Relay Outputs

P8.1 – Relay 2 Function

<b>Options:</b>	Off	Relay 2 is not used.
	Ready	The relay is open when the starter is in Ready state.
	Bypassed (default)	The relay closes when the soft start is complete (when the starting current falls below 120% of the programmed motor full load amperage) and remains closed until the beginning of a stop (either soft stop or coast to stop).
	Warning	The relay closes when the starter issues a warning (see 5 Motor Protections ).
	Fault	The relay closes when the starter is in fault state (see 5 Motor Protections).
	Low Current Flag	The relay closes when the low current flag activates while the motor is running (see parameter P8.7 Low Current Flag).
	High Current Flag	The relay closes when the high current flag activates while the motor is running (see parameter P8.8 High Current Flag).
	Motor Overload Flag	The relay closes when the motor overload flag activates (see parameter P8.9 Motor Overload Flag).
	Soft Brake Relay	The relay closes when the soft starter receives a stop signal, and remains closed until the end of soft brake.
	Reversing Contactor	The relay will control an external contactor, for reverse operation. See Reverse direction operation on page 101 for details.
	Fault Not	The relay closes when control power is applied. The relay opens if the soft starter is in fault state or if control power is lost.
	Motor Energized	The relay is closed while the soft starter is running, stopping or starting.

**Description:** Selects the function of Relay 2 (normally open).

P8.2 – Relay 2 On Delay

**Range:** 0:00 - 5:00 (minutes:seconds) **Default:** 0 second

**Description:** Sets the delay for changing the state of Relay 2.

P8.3 – Relay 2 Off Delay

**Range:** 0:00 - 5:00 (minutes:seconds) **Default:** 0 second

**Description:** Sets the delay for changing the state of Relay 2.

P8.4 – Relay 3 Function

<b>Options:</b>	Off	High Current Flag
	Ready	Motor Overload Flag
	Bypassed	Soft Brake Relay
	Warning	Reversing Contactor
	Fault (default)	Fault Not
	Low Current Flag	Motor Energized

**Description:** Selects the function of Relay 3 (normally open). See parameter P8.1 Relay 2 Function.

## 13 Programmable parameters

### 13.14 P8 Relay Outputs

#### P8.5 – Relay 3 On Delay

---

**Range:** 0:00 - 5:00 (minutes:seconds) **Default:** 0 second  
**Description:** Sets the delay for closing Relay 3.

#### P8.6 – Relay 3 Off Delay

---

**Range:** 0:00 - 5:00 (minutes:seconds) **Default:** 0 second  
**Description:** Sets the delay for re-opening Relay 3.

The soft starter has low and high current flags to give early warning of abnormal operation. The current flags can be configured to indicate an abnormal current level during operation, between the normal operating level and the undercurrent or instantaneous overcurrent trip levels. The flags can signal the situation to external equipment via one of the programmable outputs.

The flags clear when the current returns within the normal operating range by 10% of the programmed flag value.

#### P8.7 – Low Current Flag

---

**Range:** 1% - 100% FLA **Default:** 50%  
**Description:** Sets the level at which the low current flag operates, as a percentage of motor full load amperage.

#### P8.8 – High Current Flag

---

**Range:** 50% - 600% FLA **Default:** 100%  
**Description:** Sets the level at which the high current flag operates, as a percentage of motor full load amperage.



P8.7 High Current Flag and P8.8 Low Current Flag only operate in bypassed/running state.

#### P8.9 – Motor Overload Flag

---

The soft starter has a motor overload flag to give early warning of abnormal operation. The flag can be set lower than the overload limit, to indicate the motor is approaching an overload condition. The flag can signal the situation to external equipment via one of the programmable outputs.

**Range:** 0% - 160% **Default:** 80%  
**Description:** Sets the level at which the motor overload flag operates, as a percentage of the motor's thermal capacity.

### 13.15 P9 Display

P9.1 – Default Screen

<b>Options:</b>	Last Used (default)	The starter will reopen with the last screen used before power loss.
	Starter Status	The starter will reopen with the 'Starter Status' screen. See Starter status on page 68.
	Phase Currents	The starter will reopen with the current monitoring screen. See Phase current on page 68.
	Last Start Info	The starter will reopen with the last start information screen. See Last start information on page 68.
	User Display	The starter will reopen with the user configurable screen. See User configurable screen on page 69.
	Graph	The starter will reopen with the performance graph screen. See Performance graph on page 69.

**Description:** Sets the screen the soft starter returns to after power loss, or a period of button inactivity (if left in a programming menu).

P9.2 – Screen Timeout

<b>Options:</b>	1 minute (default)	4 minutes
	2 minutes	5 minutes
	3 minutes	

**Description:** Sets the timeout for the menu to automatically exit to the default screen (P9.1) if no keypad activity is detected.

P9.3 – Measurement Units

<b>Options:</b>	IEC (kW / °C) (default)
	NEMA (HP / °F)

**Description:** Selects whether the S711 will display power and temperatures in IEC or NEMA units.

P9.4 – Graph Data

The S711 has a real-time performance graph to report the behaviour of critical operating parameters.

<b>Options:</b>	Current (default)	Current as a percentage of motor full load amperage.
	Voltage	The average voltage measured on three phases as a percentage of the three-phase motor supply voltage.
	Motor Overload (%)	The motor overload percentage.
	Motor pf	Motor power factor, measured by the soft starter.

**Description:** Selects which information the graph will display.

P9.5 – Graph Timebase

<b>Options:</b>	30 seconds (default)	30 minutes
	1 minute	1 hour

**Description:** Sets the graph time scale. The graph will progressively replace the old data with new data.

## 13 Programmable parameters

### 13.15 P9 Display

#### P9.6 – Graph Maximum Adjustment

<b>Range:</b>	0% - 600%	<b>Default:</b>	400%
<b>Description:</b>	Adjusts the upper limit of the performance graph. For instance, if P9.4 Graph Data is set to 'Current' and P9.6 is set to 600%, the graph will display currents up to 600% of the set motor FLA.		

#### P9.7 – Graph Minimum Adjustment

<b>Range:</b>	0% - 600%	<b>Default:</b>	0%
<b>Description:</b>	Adjusts the lower limit of the performance graph.		

#### P9.8 – Keypad Parameter Lock

<b>Options:</b>	Read & Write (default)	Allows users to alter parameter values in the main menu.
	Read Only	Prevents users altering parameter values in the main menu. Parameter values can still be viewed.

**Description:** Selects whether the keypad will allow parameters to be changed via the main menu.

#### P9.9 – User Monitor 1

<b>Options:</b>	Blank	Displays no data in the selected area, allowing long messages to be shown without overlapping.
	Current (default)	Average rms current across all three phases
	Voltage	Average rms voltage across all three phases.
	L1 Voltage	Line 1 voltage.
	L2 Voltage	Line 2 voltage.
	L3 Voltage	Line 3 voltage.
	Mains Frequency	The average frequency measured on three phases.
	Motor pf	The motor's power factor, measured by the soft starter.
	Motor Power	The motor's running power in kilowatts or horsepower.
	Motor Overload (%)	The motor overload percentage.
	Hours Run	The number of hours the motor has run via the soft starter.
	Number of Starts	The number of starts the soft starter has completed since the start counter was last reset.
	Heatsink Temperature	The soft starter's temperature, measured at the heatsink.
	Bypass Model (%)	The percentage of thermal capacity remaining in the bypass contactor.
	SCR Temperature	The temperature of the SCRs, calculated by the thermal model.
Rating Capacity (%)	The thermal capacity available in the soft starter for its next start.	

**Description:** Selects which information will be displayed on the left side of the second line of the starter status screen.

#### P9.10 – User Monitor 2

<b>Options:</b>	See parameter P9.9 User Monitor 1 for details.	<b>Default:</b>	Voltage
<b>Description:</b>	Selects which information will be displayed on the right side of the second line of the starter status screen.		

## 13 Programmable parameters

### 13.15 P9 Display

#### P9.11 – User Monitor 3

---

**Options:** See parameter P9.9 User Monitor 1 for details. **Default:** Mains Frequency

**Description:** Selects which information will be displayed on the first line of the user configurable screen.

#### P9.12 – User Monitor 4

---

**Options:** See parameter P9.9 User Monitor 1 for details. **Default:** Motor pf

**Description:** Selects which information will be displayed on the second line of the user configurable screen.

#### P9.13 – User Monitor 5

---

**Options:** See parameter P9.9 User Monitor 1 for details. **Default:** Motor Power

**Description:** Selects which information will be displayed on the third line of the user configurable screen.

#### P9.14 – User Monitor 6

---

**Options:** See parameter P9.9 User Monitor 1 for details. **Default:** Motor Overload (%)

**Description:** Selects which information will be displayed on the fourth line of the user configurable screen.

## 13 Programmable parameters

### 13.16 P10 Fieldbus

#### 13.16 P10 Fieldbus

The soft starter offers on-board Modbus RTU.

The soft starter can connect to an Ethernet network via an optional communication card. Options are available for Ethernet/IP, Modbus TCP and Profinet.

To use the soft starter on an Ethernet network, separate addresses must be configured for:

- DHCP
- IP address
- Gateway address
- Subnet mask

Use parameters P10.5~P10.9 to set the network address.

On-board Modbus RTU is enabled by default. If not needed, we strongly recommend disabling fieldbus: set parameter P10.8 Fieldbus Select to 'Fieldbus Disabled'.

##### P10.1 – Modbus RTU Address

<b>Range:</b>	1 - 254	<b>Default:</b>	1
<b>Description:</b>	Sets the Modbus RTU network address for the soft starter.		

##### P10.2 – Modbus RTU Baud

<b>Options:</b>	4800	19200 (default)
	9600	38400
<b>Description:</b>	Selects the baud rate for Modbus RTU communication.	

##### P10.3 – Modbus RTU Parity

<b>Options:</b>	None
	Odd
	Even (default)
<b>Description:</b>	Selects the parity for Modbus RTU communication.

##### P10.4 – Modbus RTU Timeout

<b>Options:</b>	Off (default)	60 seconds
	10 seconds	100 seconds
<b>Description:</b>	Selects the timeout for Modbus RTU communication.	

##### P10.5 – IP Address

<b>Range:</b>	000.000.000.000 - 255.255.255.255	<b>Default:</b>	192.168.001.011
<b>Description:</b>	Sets the soft starter's static IP address, for Ethernet communication.		

## 13 Programmable parameters

### 13.16 P10 Fieldbus

#### P10.6 – Gateway Address

**Range:** 000.000.000.000 - 255.255.255.255 **Default:** 192.168.001.001

**Description:** Sets the network gateway address, for Ethernet communication.

#### P10.7 – Subnet Mask

**Range:** 000.000.000.000 - 255.255.255.255 **Default:** 255.255.255.000

**Description:** Sets the network subnet mask, for Ethernet communication.

#### P10.8 – Fieldbus Select

<b>Options:</b>	ComCard Static IP
	ComCard DHCP
	Modbus RTU (default)
	Fieldbus Disabled

**Description:** Selects which fieldbus the starter uses.



DHCP addressing is available with Modbus TCP and EtherNet/IP.  
DHCP addressing is not supported with Profinet.

#### P10.9 – External Network Timeout

<b>Options:</b>	Off (default)	60 seconds
	10 seconds	100 seconds

**Description:** Selects the timeout for external fieldbus communication.

## 13 Programmable parameters

### 13.17 P20 Advanced

#### 13.17 P20 Advanced

##### P20.1 – PIN 1 Access Rights

<b>Options:</b>	Unlock Parameters (default)	Allows the user to view and modify parameter settings when P1.1 PIN Access Policy is set to 'Parameters Locked' or 'Both Locked'.
	Unlock All	Allows the user to view and modify parameter settings, and access the 'Tools' menu, including simulation tests and BLE pairing when P1.1 PIN Access Policy is set to 'Parameters Locked', 'Tools Locked' or 'Both Locked'.

**Description:** Selects the access level for the associated PIN number.

##### P20.2 – Set PIN 1

**Range:** 000000 – 999999 **Default:** 000000

**Description:** Sets a 6-digit PIN to unlock the display.



#### CAUTION

If you have set a PIN and lose it, you can use the 'Factory Reset' menu to regain access. This will reset all parameters and stored user sets to the factory defaults (see Factory Reset on page 81).

If you have made a backup, you can use the S711 Connect app to reload your parameter settings. See the S711 Connect App Instructions for details.

##### P20.3 – PIN 2 Access Rights

<b>Options:</b>	Unlock Tools	Allows the user to access the 'Tools' menu, including simulation tests and BLE pairing when P1.1 PIN Access Policy is set to 'Tools Locked' or 'Both Locked'.
	Unlock Parameters	Allows the user to view and modify parameter settings when P1.1 PIN Access Policy is set to 'Parameters locked' or 'Both Locked'.
	Unlock All	Allows the user to view and modify parameter settings, and access the 'Tools' menu, including simulation tests and BLE pairing when P1.1 PIN Access Policy is set to 'Parameters Locked', 'Tools Locked' or 'Both Locked'.
	PIN 2 Disabled (default)	The stored PIN number (including factory default) is ignored.

**Description:** Selects the access level for the associated PIN number.



You cannot set PIN 2 before PIN 1. If you try, you will get a warning message.

#### P20.4 – Set PIN 2

<b>Range:</b>	000000 – 999999	<b>Default:</b>	000000
<b>Description:</b>	Sets a 6-digit PIN to unlock the display.		



#### CAUTION

If you have set a PIN and lose it, you can use the 'Factory Reset' menu to regain access. This will reset all parameters and stored user sets to the factory defaults (see Factory Reset on page 81).  
If you have made a backup, you can use the S711 Connect app to reload your parameter settings. See the S711 Connect App Instructions for details.

#### P20.5 – Main Contactor Time

<b>Range:</b>	100 – 2000 milliseconds	<b>Default:</b>	400 ms
<b>Description:</b>	Sets the delay period between the starter switching the main contactor output (terminals [13, 14]) and beginning the pre-start checks (before a start) or entering the not ready state (after a stop). Set according to the specifications of the main contactor used.		

#### P20.6 – Shunt Trip Mode

<b>Options:</b>	Disable (default)
	Enable

**Description:** Reconfigures the soft starter's main contactor output [13, 14] for use as a shunt trip relay. When the soft starter enters fault state on selected conditions, the relay will activate and the shunt trip will trigger the circuit breaker and disconnect the three-phase motor supply from the soft starter.

To select which faults will activate the shunt trip relay, use 'Action' parameters under:

- 5 Motor Protections (P5.3, P5.6, P5.9, P5.12, P5.15, P5.18, P5.21, P5.23)
- 6 Starter Protections (P6.3~P6.5)
- 7 Digital Inputs (P7.3, P7.8).



If shunt trip operation is enabled, certain faults may cause the shunt relay to open the circuit breaker.



If shunt trip operation is enabled, the shunt trip relay will activate for certain non-adjustable faults as well as the selected adjustable faults.

The following faults are non-adjustable:

- Current at Stop
- Current Read Err Lx
- Firing Fail Px
- Instantaneous Overcurrent
- Motor Connection
- SCR Itsm
- VZC Fail Px

## 13 Programmable parameters

### 13.17 P20 Advanced

#### P20.7 – Remote LED Mode

<b>Options:</b>	Fieldbus Control	The 'Remote' LED is on when the command source (P1.4) is set to 'Communication Card' (plug-in communication card) or 'On-board Modbus RTU'.
	Terminal Control (default)	The 'Remote' LED is on when the command source (P1.4) is set to 'Terminal'.
	Bus or Terminal Control	The 'Remote' LED is on when the command source (P1.4) is set to 'Communication Card' (plug-in communication card) or 'On-board Modbus' or 'Terminal'.

**Description:** Sets the behaviour of the 'Remote' LED on the keypad. Note that the 'Remote' LED is off when the command source (P1.4) is set to 'Keypad'.

#### P20.8 – Current Calibration

**Range:** 85% - 115% **Default:** 100%

**Description:** Calibrates the soft starter's current monitoring circuits to match an external current metering device.  
Use the following formula to determine the necessary adjustment:

$$\text{Calibration (\%)} = \frac{\text{Current shown on soft starter display}}{\text{Current measured by external device}}$$

#### P20.9 – Tracking Gain

**Range:** 1% - 200% **Default:** 50%

**Description:** Fine-tunes the behaviour of the pump control algorithm.

#### P20.10 – Pedestal Detect

**Range:** 0% - 200% **Default:** 80%

**Description:** Adjusts the behaviour of the pump control algorithm for soft stop.

#### P20.11 – Fire Mode Enable

<b>Options:</b>	Disable (default)
	Enable

**Description:** Enables 'Fire Mode'. Fire mode allows the soft starter to run the motor and ignore fault conditions. See also P7.1 Input 3 Function, P7.7 Input 4 Function and Fire mode on page 87.



Parameters P20.12 to P20.15 are read only. They can only be adjusted by an authorised service agent.

## P20.12 – Model Rating

**Range:** Model dependent

**Description:** The soft starter's internal model reference, as shown on the silver nameplate label on the side of the unit [1].



Figure 43: Model reference on nameplate

## P20.13 – CT PCB Revision

**Range:** 0 - 99

**Description:** Indicates the version of CT PCB installed in the soft starter.

## P20.14 – Gate PCB Revision

**Range:** 0 - 99

**Description:** Indicates the version of gate drive PCB installed in the soft starter.

## P20.15 – Backplane PCB Revision

**Range:** 0 - 99

**Description:** Indicates the version of backplane PCB installed in the soft starter.

## 14 Troubleshooting

### 14.1 Protection responses

## 14 Troubleshooting

### 14.1 Protection responses

When a protection condition is detected, the soft starter will write this to the event log. The soft starter's response depends on the protection action settings (see P5 Motor Protections).

Some protection responses cannot be adjusted by the user. These faults are usually caused by external events (such as phase loss) or by an internal fault of the soft starter. These faults do not have associated parameters and cannot be set to 'Warning' or 'Log Only'.

If the soft starter is in fault state you will need to identify and clear the condition that triggered the fault, then reset the soft starter before restarting. To reset the starter, press the **RESET** button on the keypad or activate the Reset remote input.

If the soft starter has issued a warning, the soft starter will reset itself once the cause of the warning has been resolved.

## 14.2 Fault messages

Table 20: Fault messages

Display	Possible cause/Suggested solution
2-Phase - Damaged SCR	This message is displayed if the soft starter has detected a 'Lx-Tx Shorted' fault during the pre-start checks (this could be due to a shorted SCR or a welded bypass contactor), and 'Two-phase Control' is enabled. It indicates that the starter now operates in two-phase control mode. If more than one phase is shorted, you cannot use two-phase control. Related parameters: P6.5
Bypass Fail	Some models use magnetic latching bypass contactors. If the starter determines that there is insufficient voltage present to guarantee operation of the contactors, it will trip on 'Bypass Fail'. This is most likely to occur where the 24 V supply does not meet the rating specified (see Supply on page 44). As a result, the bypass driver fails to charge to full voltage in the expected time. Related parameters: None
Current at Stop	The starter has detected current at a time when no current is expected (ie while the starter is in any state other than 'Starting', 'Running', 'Stopping', or while it's performing a check for a shorted phase). <ul style="list-style-type: none"> <li>If the motor is connected inside delta (six-wire connection) and no main contactor is installed, a shorted phase will be passing current to the motor.</li> </ul> Related parameters: None
Current Imbalance	Current imbalance can be caused by problems with the motor, the environment or the installation, such as: <ul style="list-style-type: none"> <li>An imbalance in the incoming three-phase motor supply</li> <li>A problem with the motor windings</li> <li>A light load on the motor</li> <li>A phase loss on input terminals L1, L2 or L3 during Run mode</li> <li>An SCR that has failed open circuit. A failed SCR can only be definitely diagnosed by replacing the SCR and checking the starter's performance.</li> </ul> Related parameters: P5.1, P5.2, P5.3
Current Read Err Lx	Where 'X' is 1, 2 or 3. Internal fault (PCB fault). The output from the CT circuit is not close enough to zero when the SCRs are turned off. Contact your local supplier for advice. Related parameters: None
Excess Start Time	Excess start time fault can occur in the following conditions: <ul style="list-style-type: none"> <li>P2.1 Motor FLA is too low for the motor</li> <li>P3.4 Current Limit has been set too low</li> <li>P3.2 Start Ramp Time has been set greater than the setting for P5.22 Excess Start Time</li> <li>P5.22 Excess Start Time is set too short for a high inertia load</li> </ul> This fault can also occur if the secondary motor parameters are incorrect. Related parameters: P2.1, P3.2, P3.4, P4.1, P4.4, P4.6, P5.22
Firing Fail Px	Where 'X' is phase 1, 2 or 3. The SCR did not fire as expected. The SCR may be faulty or there may be an internal wiring fault. Related parameters: None
FLA Too High	Occurs if the keypad full load amperage (FLA) setting exceeds the maximum FLA of the starter it is installed on. This typically happens when a keypad programmed for a larger starter is connected to a smaller starter. Related parameters: P2.1, P2.5, P4.1
Frequency	The mains frequency has gone beyond the specified range. If the soft starter is connected to a generator set supply, the frequency limits could be too tight. Related parameters: P5.27, P5.28, P5.29, P5.30

## 14 Troubleshooting

### 14.2 Fault messages

Display	Possible cause/Suggested solution
Heatsink Overtemperature	<ul style="list-style-type: none"> <li>• Check that all busbar connections are tight.</li> <li>• Check that cooling fans (if fitted) are operating and airflow is unobstructed at both ends of the heatsink.</li> <li>• If mounted in an enclosure, check if ventilation is adequate.</li> <li>• The soft starter can be mounted up to 15° from vertical.</li> <li>• Check that bypass contactors are operating: use the 'Output Signal Test' (see Output signal test on page 71). Use a multimeter to verify continuity L1-T1, L2-T2, L3-T3.</li> </ul> <p>Related parameters: None</p>
Input 3 Fault Input 4 Fault	<p>The soft starter's programmable input is set to an external fault function and has activated. Resolve the trigger condition.</p> <p>Related parameters: P7.1~P7.5, P7.7~P7.11</p>
Instantaneous Overcurrent	<p>This fault is not adjustable.</p> <p>The current on all three phases has exceeded 7.2 times the value of parameter P2.1 Motor FLA or P4.1 Motor FLA-2.</p> <p>Causes can include a locked rotor condition or an electrical fault in the motor or cabling.</p> <p>Related parameters: None</p>
Keypad Disconnected	<p>The keypad was disconnected with control power on.</p> <p>Ensure that the keypad is firmly connected to the starter.</p>
L1 Phase Loss L2 Phase Loss L3 Phase Loss	<p>This fault is not adjustable.</p> <p>During pre-start checks the starter has detected a phase loss as indicated.</p> <p>In Run or Jog state, the starter has detected that the current on the affected phase has dropped below 10% of the programmed motor FLA for more than 1 second, indicating that either the incoming phase or connection to the motor has been lost.</p> <p>Check the supply and the input and output connections at the starter and at the motor end.</p> <p>Related parameters: None</p>
L1-T1 Shorted L2-T2 Shorted L3-T3 Shorted	<p>During pre-start checks the starter has detected a shorted SCR or bypass contactor.</p> <p>Consider using 'Two-phase Control' to allow operation until the starter can be repaired.</p> <p>Related parameters: P6.5</p>
Low Control Volts	<p>The soft starter has detected a drop in the internal control voltage.</p> <ul style="list-style-type: none"> <li>• Check the external control supply (AC: N, L; DC: -, +) and reset the starter.</li> </ul> <p>If the external control supply is stable:</p> <ul style="list-style-type: none"> <li>• there may be an internal fault; or</li> <li>• the bypass driver PCB may be faulty. Contact your local supplier for advice.</li> </ul> <p>This protection is not active in Ready state.</p> <p>Related parameters: None</p>
Motor Connection Motor Connection T1 Motor Connection T2 Motor Connection T3	<p>This fault is not adjustable.</p> <p>The motor is not connected correctly to the soft starter.</p> <ul style="list-style-type: none"> <li>• Check individual motor connections to the soft starter for power circuit continuity.</li> <li>• Check connections at the motor terminal box.</li> </ul> <p>Related parameters: None</p>
Motor Overload	<p>The motor overload has reached its maximum capacity. Overload can be caused by:</p> <ul style="list-style-type: none"> <li>• The soft starter protection settings not matching the motor and application</li> <li>• Excessive starts per hour or start duration</li> <li>• Excessive current</li> </ul> <p>Resolve the cause of the overload and allow the motor to cool.</p> <p>Related parameters: P2.1, P2.4, P4.1, P5.22, P5.23</p> <p>→ Check the requirements from the applicable local electrical code.</p>

Display	Possible cause/Suggested solution
Motor Thermistor	<p>The motor thermistor input has been enabled and:</p> <ul style="list-style-type: none"> <li>• The resistance at the thermistor input has exceeded 3.6 kΩ for more than one second.</li> <li>• The motor winding has overheated. Identify the cause of the overheating and allow the motor to cool before restarting.</li> <li>• The motor thermistor input has been opened.</li> </ul> <p>If thermistors have previously been connected to the soft starter but are no longer required, use the Thermistor Reset function to disable the thermistor.</p> <p>Related parameters: P6.4</p>
Network Communication	<p>There is a network communication problem, or the network master may have sent a fault command to the starter. Check the network for causes of communication inactivity.</p> <p>Related parameters: P6.3</p>
Not Ready	<ul style="list-style-type: none"> <li>• The Enable/Reset input may be activated.</li> <li>• The soft starter may be waiting for the restart delay to elapse. The length of the restart delay is controlled by parameter P5.24 Restart Delay.</li> <li>• Starts per hour may have been exceeded.</li> </ul> <p>Related parameters: P5.24, P5.25</p>
Overcurrent	<p>The current has exceeded the level set in parameter P5.7 Overcurrent for longer than the time set in parameter P5.8 Overcurrent Delay. Causes can include a momentary overload condition that exceeds the trip threshold.</p> <p>Related parameters: P5.7, P5.8, P5.9</p>
Overpower	<p>The motor has experienced a rise in power. Causes can include a momentary overload condition which has exceeded the adjustable delay time.</p> <p>Related parameters: P5.19, P5.20, P5.21</p>
Overvoltage	<p>A voltage surge, above the set level, occurred on the mains. Causes can include problems with a transformer tap regulator or off-loading of a large transformer load.</p> <p>Related parameters: P5.13, P5.14, P5.15</p>
Param xx Out of Range	<p>This fault is not adjustable.</p> <ul style="list-style-type: none"> <li>• A parameter value is outside the valid range. The keypad will indicate the first invalid parameter.</li> <li>• The parameter set or values in the keypad do not match the parameters in the starter. Edit the parameter value on the keypad, press <b>➤</b>, then press Reset. If the problem persists, contact your local distributor.</li> </ul> <p>Related parameters: None</p>
Phase Sequence	<p>The phase sequence on the soft starter's input terminals (L1, L2, L3) does not match the sequence set in parameter P5.26.</p> <p>Check the phase sequence on L1, L2, L3 and ensure the setting in parameter P5.26 is suitable for the installation.</p> <p>Related parameters: P5.26</p>
Power Loss	<p>This fault is not adjustable.</p> <p>The three-phase motor supply is not present on one or more phases.</p> <ul style="list-style-type: none"> <li>• Check that the main contactor closes when a start command is given, and remains closed until the end of a soft stop.</li> <li>• Check the fuses.</li> </ul> <p>If testing the soft starter with a small motor, it must draw at least 10% of the starter's programmed FLA setting on each phase.</p> <p>Related parameters: None</p>
Rating Capacity	<p>The soft starter is operating beyond its safe capacity. Allow the starter to cool.</p> <p>Related parameters: None</p>
SCR Itsm	<p>The SCR current surge rating has been exceeded.</p> <p>Related parameters: None</p>
SCR Overtemperature	<p>The temperature of the SCRs, calculated by the thermal model, is too high to allow further operation. Wait for the starter to cool.</p> <p>Related parameters: None</p>

## 14 Troubleshooting

### 14.2 Fault messages

Display	Possible cause/Suggested solution
Starter Communication	There is a problem with the connection between the soft starter and the optional communication card. Remove and reinstall the card. If the problem persists, contact your local distributor. Related parameters: None
Starts Per Hour	The soft starter has already attempted the maximum number of starts in the last 60 minutes. Wait for the starter to return to Ready before attempting another start. To determine when the waiting period will end, review the log. If appropriate, you can disable this protection by setting P5.25 to 0. You can also enable additional starts by increasing the setting of P5.25.. Related parameters: P5.25
Thermistor Circuit	The thermistor input has been enabled and: <ul style="list-style-type: none"> <li>• The resistance at the input has fallen below 20 <math>\Omega</math> (the cold resistance of most thermistors will be over this value) or</li> <li>• A short circuit has occurred. Check and resolve this condition.</li> </ul> Related parameters: None
Time-Overcurrent (bypass overload)	The soft starter's internal bypass contactor's overload limit has been exceeded, due to excessive current in running state. Related parameters: None
Undercurrent	Motor current has fallen below the level selected. This is usually due to a reduced load. Causes can include broken components (shafts, belts or couplings), or a pump running dry. Related parameters: P5.4, P5.5, P5.6
Underpower	Motor power has fallen below the level selected. This is usually due to a reduced load. Causes can include broken components (shafts, belts or couplings), or a pump running dry. Related parameters: P5.16, P5.17, P5.18
Undervoltage	Three-phase motor supply voltage has fallen below the level selected. Causes can include an undersized supply or adding a large load to the system. Related parameters: P5.10, P5.11, P5.12
VZC Fail Px	Where 'X' is 1, 2 or 3. Internal fault (PCB fault). Contact your local supplier for advice. Related parameters: None
Zero Speed Detect	The zero speed input has not closed within the expected duration of a soft brake or DC brake. <ul style="list-style-type: none"> <li>• Check the zero speed sensor is operating correctly.</li> <li>• For DC brake, check that parameters P3.10 Stop Time and P3.16 DC Brake Time are set appropriately for the application.</li> <li>• For soft brake, check that parameters P3.17 Brake Current Limit and P5.22 Excess Start Time are set appropriately for the application.</li> </ul> Related parameters: P3.10, P3.16, P3.17, P4.12, P4.18, P4.19, P5.22

## 14.3 General faults



This table describes situations where the soft starter does not operate as expected but does not have an active fault or give a warning.

Table 21: General faults

Symptom	Probable Cause
'Sim' on display	<ul style="list-style-type: none"> <li>The starter is running in simulation mode. This feature is intended only for demonstration and to check control wiring. It is not suitable for controlling a motor. To return to motor control mode, use the 'Tools' menu, or cycle the control power.</li> </ul>
The soft starter does not respond to commands from the digital inputs.	<ul style="list-style-type: none"> <li>The soft starter will only accept commands from the inputs if parameter P1.4 Command Source is set to 'Terminal'. Check the setting of P1.4. (The soft starter will accept reset commands from the inputs, independent of the command source.)</li> <li>The control wiring may be incorrect. Check that the remote start, stop and reset inputs are configured correctly (see Start/Stop on page 52 for details).</li> <li>The signals to the inputs may be incorrect. Test the signalling by activating each input signal in turn.</li> </ul>
The soft starter does not respond to a start command from either the keypad or the digital inputs.	<ul style="list-style-type: none"> <li>The soft starter may be waiting for the restart delay to elapse. The length of the restart delay is controlled by parameter P5.24 Restart Delay.</li> <li>The motor may be too hot to permit a start. The soft starter will only permit a start when it calculates that the motor has sufficient thermal capacity to complete the start successfully. Wait for the motor to cool before attempting another start.</li> <li>The Enable/Reset input may be activated.</li> <li>The keypad or digital inputs are not the configured command source (see parameter P1.4 Command Source).</li> </ul>
Cannot connect the mobile device to the starter	<ul style="list-style-type: none"> <li>Ensure that Bluetooth has been enabled on the mobile device and that pairing has been initiated.</li> <li>Ensure that P1.2 BLE Access Policy is not set to 'BLE not allowed'.</li> </ul> <p>The keypad does not have valid firmware installed.</p> <ul style="list-style-type: none"> <li>In these cases, Bluetooth automatic pairing mode is enabled for a grace period of 60 seconds, immediately after control power is applied to the starter. Use this delay to pair the starter with the app and initiate a firmware update.</li> <li>If you cannot establish a connection during this period (you get two connection attempts), BLE is disabled until control power is cycled again.</li> </ul>
Erratic and noisy motor operation.	<ul style="list-style-type: none"> <li>If the soft starter is connected to the motor using inside delta configuration, ensure that parameter P2.5 Motor Connection is set to 'Inside Delta'. If P2.5 is set correctly, contact your local supplier for advice.</li> </ul>
The soft starter does not control the motor correctly during starting.	<ul style="list-style-type: none"> <li>Start performance may be unstable when using a low Motor FLA setting (parameter P2.1).</li> <li>Power factor correction (PFC) capacitors must be installed on the supply side of the soft starter and must be disconnected during starting and stopping. To use the soft starter to control power factor correction, connect the PFC contactor to a programmable relay set to 'Bypassed'.</li> <li>High levels of harmonics on the three-phase motor supply can affect soft starter performance. If variable speed drives are installed nearby, check they are properly grounded and filtered.</li> </ul>

## 14 Troubleshooting

### 14.3 General faults

Symptom	Probable Cause
Motor does not reach full speed.	<ul style="list-style-type: none"> <li>If the start current is too low, the motor will not produce enough torque to accelerate to full speed. The soft starter may trip on excess start time.</li> </ul> <p>→ Make sure the motor starting parameters are appropriate for the application and that you are using the intended motor starting profile. If a programmable input is set to 'Second Motor Select', check that the corresponding input is in the expected state.</p> <ul style="list-style-type: none"> <li>The load may be jammed. Check the load for severe overloading or a locked rotor situation.</li> </ul>
Soft stop ends too quickly.	<ul style="list-style-type: none"> <li>The soft stop settings may not be appropriate for the motor and load. Review the soft stop settings.</li> <li>If the motor is very lightly loaded, soft stop will have limited effect.</li> </ul>
After selecting pump control the motor used an ordinary start and/or the second start was different to the first.	<ul style="list-style-type: none"> <li>The first pump control start is actually 'Constant Current' so that the starter can learn from the motor characteristics. Subsequent starts use pump control. See also Pump control for starting on page 94.</li> </ul>
'Two-phase Control' does not operate when selected.	<ul style="list-style-type: none"> <li>The starter will activate the fault 'Lx-Tx Shorted' on the first start attempt after control power is applied. Two-phase control will not operate if control power is cycled between starts. See also Two-phase control on page 86.</li> </ul>
Parameter settings cannot be stored.	<ul style="list-style-type: none"> <li>Make sure you are saving the new value by pressing the button  after adjusting a parameter setting. If you press , the change will not be saved. The soft starter does not display a confirmation.</li> <li>Check that the keypad parameter lock (parameter P9.8) is set to 'Read &amp; Write'. If the keypad parameter lock is set to 'Read Only', settings can be viewed but not changed.</li> <li>If P1.1 PIN Access Policy is set to 'Parameters Locked', enter the security PIN to enable parameter changes.</li> </ul>
'Rating Not Valid'	The value of parameter P20.12 Model Rating is incorrect. Parameter P20.12 is not user-adjustable. Contact your local supplier for advice.

## 14.4 Starter LEDs

When the keypad is detached, the starter LEDs are visible in the keypad recess.

- The green 'Run' LED indicates the starter state.
- The red 'Trip' LED indicates faults.

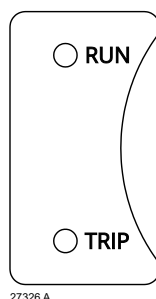

Figure 44: Starter LEDs



When the keypad is disconnected, it no longer controls the starter.

If the motor is operating when the keypad is disconnected, the starter faults to de-energise the motor and put it into a safe state.

If the starter is 'Ready' when the keypad is disconnected, the motor is already in a safe (de-energised) state, and the starter faults.

For the starter to operate, the keypad must be connected to the starter with a patch cable.

See Removable keypad on page 65.

Table 22: Starter LEDs behaviour

LED name	On/Flashing	Indication	Description
Run (green)	Flashing (continuous)	Bootloader	When troubleshooting, use to diagnose the starter state.
	Flashing * 1	Initialising	
	Flashing * 2	Waiting	
	Flashing * 3	Pre-start	
	Flashing * 4	Starting	
	Flashing * 5	Running	
	Flashing * 6	Stopping	
Trip (red)	On	Power loss	This indicates a power loss shutdown sequence. Normal communication is halted, which can result in unusual behaviour.
	Flashing * 4	Communication fail	The starter has not received any message from the keypad, within five seconds. This indicates the fault is with the keypad or the hardware.

## 15 Appendix

### 15.1 Modbus RTU register map

Modbus RTU register numbers are listed in the tables below.

The addresses are one digit less than the register number, eg register 40001 = address 40000.

UINT32 variables are stored in big-endian format: the most significant register is transmitted first and the least significant register is transmitted last.

➔ Read only parameters prevent inadvertent changes that could change access rights or lose communication.

➔ You must read parameters with two registers as register pairs.

#### 15.1.1 Register map summary

Table 23: Register map summary

Register map summary		Start register	Allowed Modbus RTU function code(s)	
Info type	Starter responds to overlapped registers with either FC3 or FC4 on a read	Start register for auto-generated tables	Read	Write
Write control command	30001/40001	40001		FC6/FC16
Starter info read	31001/41001	41001	FC3/FC4	
Real-time data read	32001/42001	42001	FC3/FC4	
Counters read	33001/43001	43001	FC3/FC4	
Parameter read/write	34001/44001	44001	FC3/FC4	FC6/FC16

### 15.1.2 Command register

Table 24: Command register

<b>Register 40001</b>	
<b>Bit</b>	<b>Details</b>
Bit 0	Stop/Run
Bit 1	Fault Reset
Bit 2	Jog Forward
Bit 3	Jog Reverse
Bit 4	Fault (add forced comms fault code)
Bits 5-9	<i>Reserved</i>
Bit 10	0 = Start/Stop Set 1 1 = Start/Stop Set 2, if Command Source = 'On-board Modbus RTU'
Bit 11	0= Programmed stop 1= Coast to Stop, if Command Source = 'On-board Modbus RTU'
Bits 12-15	<i>Reserved</i>

## 15 Appendix

### 15.1 Modbus RTU register map

#### 15.1.3 Starter about info

For registers 41030-41037 to return valid data, they must be read with the protocol matching the installed communications card. When read over Modbus RTU, these registers will always return 0.

Table 25: Starter about info

Register	Description
41001	Model number
41002	Starter current rating
41003	Starter voltage rating
41004	Starter serial number (msd)
41005	
41006	
41007	
41008	
41009	
41010	
41011	Starter serial number (lsd)
41012	Starter parameter list version - Major Major
41013	Starter parameter list version - minor minor
41014	MCM version - DATE YYYY
41015	MCM version - DATE MM
41016	MCM version - DATE DD
41017	MCM version - MICRO TYPE
41018	MCM version - PCB VARIANT and REV
41019	MCM version - SPARE
41020	MCM version FIRMWARE - Major Major
41021	MCM version FIRMWARE - minor minor minor
41022	HMI version - DATE YYYY
41023	HMI version - DATE MM
41024	HMI version - DATE DD
41025	HMI version - MICRO TYPE
41026	HMI version - PCB VARIANT and REV
41027	S711 product ID
41028	HMI version FIRMWARE - Major Major
41029	HMI version FIRMWARE - minor minor minor
41030	COMM version - DATE YYYY
41031	COMM version - DATE MM
41032	COMM version - DATE DD
41033	COMM version - SPARE
41034	COMM version - SPARE
41035	COMM version - SPARE
41036	COMM version FIRMWARE - Major Major
41037	COMM version FIRMWARE - minor minor minor

## 15.1.4 Real-time data

Table 26: Real-time data

Register	Description	Details	
42001	Starter state (See Starter state on page 158 for details.)	UINT16	
42002	Starter fault/warning code		
42003	Average current		
42004	Line 1 current		
42005	Line 2 current		
42006	Line 3 current		
42007	Current imbalance		
42008	Average voltage		
42009	Line 1 voltage		
42010	Line 2 voltage		
42011	Line 3 voltage		
42012	Control supply voltage		
42013	Phase sequence		
42014	Frequency		
42015	Power factor		
42016	Power (kW or HP)		
42017	kVA		
42018	kVAR		
42019	Motor 1 overload		
42020	Motor 1 overload - seconds till clear		
42021	Starts/hour count		
42022	Starts/hour - seconds till clear		
42023	Restart delay - seconds till clear		
42024	Heatsink temperature		
42025	SCR temperature		
42026	Digital IO state		Bitmap
42027	IO relay status		Bitmap
42028	Current as % of FLA		UINT16
42029	Flags bit wise (warning, LED) 0: Warning bit (1 if a trip or warning is present; 0 else) 1: Remote flag (must match LED on HMI) 2 to 7: Reserved	Bitmap	

## 15 Appendix

### 15.1 Modbus RTU register map

#### 15.1.4.1 Starter state

Table 27: Starter state

Register 42001	
Value	Details
0	Initialising
1	Ready
2	Main contactor close
3	Starting
4	Running
5	Stopping
6	Soft braking
7	Main contactor open
8	Not ready
9	Fault present
10	Jog
11	Output test
12	Suspended
13	Power down
14	Pre-start
15	Not used

#### 15.1.5 Counters

Table 28: Counters

Register	Counters	Details
43001	Number of starts (resettable)	UINT16
43002	Number of starts (lifetime)	
43003	Number of failed starts (resettable)	
43004	Number of failed starts (lifetime)	
43005	Number of faults (resettable)	
43006	Number of faults (lifetime)	
43007	kWh (resettable)	UINT32
43008		
43009	kWh (lifetime)	
43010		
43011	Hours run (resettable)	
43012		
43013	Hours run (lifetime)	
43014		

## 15.1 Modbus RTU register map

## 15.1.6 User parameters

Registers marked with an asterisk are UINT32. All other registers are UINT16.

All registers are Read/Write, unless otherwise stated.

Reading PIN 1 or PIN 2 will always return "0x0000".

Table 29: User parameters

Register	Description	Parameter number	Parameter group/number	Details
44001	PIN Access Policy	1	P1.1	Read only
44002	BLE Access Policy	2	P1.2	Read only
44003	Language	3	P1.3	
44004	Command Source	4	P1.4	
44005	Motor FLA	5	P2.1	
44006	Motor Power	6	P2.2	
44007	Trip Class	7	P2.3	
44008	Motor Service Factor	8	P2.4	
44009	Motor Connection	9	P2.5	
44010	Efficiency Class	10	P2.6	
44011	Start Mode	11	P3.1	
44012	Start Ramp Time	12	P3.2	
44013	Initial Current	13	P3.3	
44014	Current Limit	14	P3.4	
44015	Pump Start Profile	15	P3.5	
44016	Kickstart Time	16	P3.6	
44017	Kickstart Level	17	P3.7	
44018	Jog Torque	18	P3.8	
44019	Stop Mode	19	P3.9	
44020	Stop Time	20	P3.10	
44021	Pump Stop Profile	21	P3.11	
44022	Pump Control Gain	22	P3.12	
44023	Multi Pump	23	P3.13	
44024	Start Delay	24	P3.14	
44025	DC Brake Torque	25	P3.15	
44010	DC Brake Time	26	P3.16	
44027	Brake Current Limit	27	P3.17	
44028	Soft Brake Delay	28	P3.18	
44029	Motor FLA-2	29	P4.1	
44030	Motor Power-2	30	P4.2	
44031	Start Mode-2	31	P4.3	
44032	Start Ramp Time-2	32	P4.4	
44033	Initial Current-2	33	P4.5	
44034	Current Limit-2	34	P4.6	
44035	Pump Start Profile-2	35	P4.7	
44036	Kickstart Time-2	36	P4.8	
44037	Kickstart Level-2	37	P4.9	
44038	Jog Torque-2	38	P4.10	
44039	Stop Mode-2	39	P4.11	

## 15 Appendix

### 15.1 Modbus RTU register map

Register	Description	Parameter number	Parameter group/number	Details
44040	Stop Time-2	40	P4.12	
44041	Pump Stop Profile-2	41	P4.13	
44042	Pump Control Gain-2	42	P4.14	
44043	Multi Pump-2	43	P4.15	
44044	Start Delay-2	44	P4.16	
44045	DC Brake Torque-2	45	P4.17	
44046	DC Brake Time-2	46	P4.18	
44047	Brake Current Limit-2	47	P4.19	
44048	Soft Brake Delay-2	48	P4.20	
44049	Current Imbalance	49	P5.1	
44050	Current Imbalance Delay	50	P5.2	
44051	Current Imbalance Action	51	P5.3	
44052	Undercurrent	52	P5.4	
44053	Undercurrent Delay	53	P5.5	
44054	Undercurrent Action	54	P5.6	
44055	Overcurrent	55	P5.7	
44056	Overcurrent Delay	56	P5.8	
44057	Overcurrent Action	57	P5.9	
44058	Undervoltage	58	P5.10	
44059	Undervoltage Delay	59	P5.11	
44060	Undervoltage Action	60	P5.12	
44061	Overvoltage	61	P5.13	
44062	Overvoltage Delay	62	P5.14	
44063	Overvoltage Action	63	P5.15	
44064	Underpower	64	P5.16	
44065	Underpower Delay	65	P5.17	
44066	Underpower Action	66	P5.18	
44067	Overpower	67	P5.19	
44068	Overpower Delay	68	P5.20	
44069	Overpower Action	69	P5.21	
44070	Excess Start Time	70	P5.22	
44071	Excess Start Time Action	71	P5.23	
44072	Restart Delay	72	P5.24	
44073	Starts per Hour	73	P5.25	
44074	Phase Sequence	74	P5.26	
44075	Max Frequency	75	P5.27	
44076	Min Frequency	76	P5.28	
44077	Frequency Delay	77	P5.29	
44078	Frequency Action	78	P5.30	
44079	Motor Overload	79	P5.31	
44080	Auto Reset Count	80	P6.1	
44081	Auto Reset Delay	81	P6.2	
44082	Fieldbus Fault Action	82	P6.3	
44083	Motor Thermistor Circuit	83	P6.4	
44084	Shorted SCR Action	84	P6.5	
44085	Input 3 Function	85	P7.1	
44086	Input 3 Fault	86	P7.2	
44087	Input 3 Fault Action	87	P7.3	
44088	Input 3 Fault Delay	88	P7.4	
44089	Input 3 Initial Delay	89	P7.5	

## 15.1 Modbus RTU register map

Register	Description	Parameter number	Parameter group/number	Details
44090	Input 3 Fault Name	90	P7.6	
44091	Input 4 Function	91	P7.7	
44092	Input 4 Fault	92	P7.8	
44093	Input 4 Fault Action	93	P7.9	
44094	Input 4 Fault Delay	94	P7.10	
44095	Input 4 Initial Delay	95	P7.11	
44096	Input 4 Fault Name	96	P7.12	
44097	Enable/Reset Logic	97	P7.13	
44098	Relay 2 Function	98	P8.1	
44099	Relay 2 On Delay	99	P8.2	
44100	Relay 2 Off Delay	100	P8.3	
44101	Relay 3 Function	101	P8.4	
44102	Relay 3 On Delay	102	P8.5	
44103	Relay 3 Off Delay	103	P8.6	
44104	Low Current Flag	104	P8.7	
44105	High Current Flag	105	P8.8	
44106	Motor Overload Flag	106	P8.9	
44107	Default Screen	107	P9.1	
44108	Screen Timeout	108	P9.2	
44109	Measurement Units	109	P9.3	
44110	Graph Data	110	P9.4	
44111	Graph Timebase	111	P9.5	
44112	Graph Maximum Adjustment	112	P9.6	
44113	Graph Minimum Adjustment	113	P9.7	
44114	Keypad Parameter Lock	114	P9.8	
44115	User Monitor 1	115	P9.9	
44116	User Monitor 2	116	P9.10	
44117	User Monitor 3	117	P9.11	
44118	User Monitor 4	118	P9.12	
44119	User Monitor 5	119	P9.13	
44120	User Monitor 6	120	P9.14	
44121	Modbus RTU Address	121	P10.1	
44122	Modbus RTU Baud	122	P10.2	
44123	Modbus RTU Parity	123	P10.3	
44124	Modbus RTU Timeout	124	P10.4	
44125*	IP Address	125	P10.5	
44126*				
44127*	Gateway Address	126	P10.6	
44128*				
44129*	Subnet Mask	127	P10.7	
44130*				Read Only
44131	Fieldbus Select	128	P10.8	
44132	External Network Timeout	129	P10.9	
44133	PIN 1 Access Rights	130	P20.1	
44134	Set PIN 1	131	P20.2	
44135	PIN 2 Access Rights	132	P20.3	
44136	Set PIN 2	133	P20.4	
44137	Main Contactor Time	134	P20.5	
44138	Shunt Trip Mode	135	P20.6	
44139	Remote LED Mode	136	P20.7	
44140	Current Calibration	137	P20.8	

## 15 Appendix

### 15.1 Modbus RTU register map

Register	Description	Parameter number	Parameter group/number	Details
44141	Tracking Gain	138	P20.9	
44142	Pedestal Detect	139	P20.10	
44143	Fire Mode Enable	140	P20.11	
44144	Model Rating	141	P20.12	Read Only
44145	CT PCB Revision	142	P20.13	
44146	Gate PCB Revision	143	P20.14	
44147	Backplane PCB Revision	144	P20.15	

## 15.2 Fault codes

Table 30: Fault codes

<b>Fault code</b>	<b>Description</b>
0	2 Phase - Damaged SCR
1	Excess Start Time
2	Motor Overload (thermal model)
3	Motor Thermistor
4	Current Imbalance
5	Frequency
6	Phase Sequence
7	Overcurrent
8	Power Loss
9	Undercurrent
10	Heatsink Overtemperature
11	Motor Connection
12	Input 3 Fault
13	FLA Too High
15	Communication Card Fault
16	Network Communication
18	Overvoltage
19	Undervoltage
24	Input 4 Fault
25	Bypass Fail
26	L1 Phase Loss
27	L2 Phase Loss
28	L3 Phase Loss
29	L1-T1 Shorted
30	L2-T2 Shorted
31	L3-T3 Shorted
33	Time-Overcurrent (bypass overload)
34	SCR Overtemperature
36	Motor Thermistor
47	Overpower
48	Underpower
57	Zero Speed Detect
58	SCR Itsm
59	Instantaneous Overcurrent
60	Rating Capacity
70	Current Read Err L1
71	Current Read Err L2
72	Current Read Err L3
74	Motor Connection T1
75	Motor Connection T2
76	Motor Connection T3
77	Firing Fail P1
78	Firing Fail P2
79	Firing Fail P3
80	VZC Fail P1
81	VZC Fail P2
82	VZC Fail P3

## 15 Appendix

### 15.2 Fault codes

<b>Fault code</b>	<b>Description</b>
83	Low Control Volts
96	Keypad Disconnected
129	Current at Stop

## 15.3 User parameter settings

	Parameter Group	Default Setting	User Notes
<b>1</b>	<b>User Configuration</b>		
P1.1	PIN Access Policy	Select PIN Configuration	
P1.2	BLE Access Policy	Select BLE Configuration	
P1.3	Language	English	
P1.4	Command Source	Keypad	
<b>2</b>	<b>Motor Details</b>		
P2.1	Motor FLA	2 A	
P2.2	Motor Power	1 kW	
P2.3	Trip Class	10	
P2.4	Motor Service Factor	105%	
P2.5	Motor Connection	In-line	
P2.6	Efficiency Class	IE4	
<b>3</b>	<b>Motor Start/Stop 1</b>		
P3.1	Start Mode	Constant Current	
P3.2	Start Ramp Time	00:10 (mm:ss)	
P3.3	Initial Current	200%	
P3.4	Current Limit	350%	
P3.5	Pump Start Profile	Constant Acceleration	
P3.6	Kickstart Time	000 ms	
P3.7	Kickstart Level	500%	
P3.8	Jog Torque	50%	
P3.9	Stop Mode	Coast to Stop	
P3.10	Stop Time	00:10 (mm:ss)	
P3.11	Pump Stop Profile	Constant Deceleration	
P3.12	Pump Control Gain	75%	
P3.13	Multi Pump	Single Pump	
P3.14	Start Delay	00:00 (mm:ss)	
P3.15	DC Brake Torque	20%	
P3.16	DC Brake Time	001 ms	
P3.17	Brake Current Limit	250%	
P3.18	Soft Brake Delay	400 ms	
<b>4</b>	<b>Motor Start/Stop 2</b>		
P4.1	Motor FLA-2	2 A	
P4.2	Motor Power-2	1 kW	
P4.3	Start Mode-2	Constant Current	
P4.4	Start Ramp Time-2	00:10 (mm:ss)	
P4.5	Initial Current-2	200%	
P4.6	Current Limit-2	350%	
P4.7	Pump Start Profile-2	Constant Acceleration	
P4.8	Kickstart Time-2	000 ms	
P4.9	Kickstart Level-2	500%	
P4.10	Jog Torque-2	50%	
P4.11	Stop Mode-2	Coast To Stop	
P4.12	Stop Time-2	00:10 (mm:ss)	
P4.13	Pump Stop Profile-2	Constant Deceleration	
P4.14	Pump Control Gain-2	75%	
P4.15	Multi Pump-2	Single Pump	

## 15 Appendix

### 15.3 User parameter settings

	Parameter Group	Default Setting	User Notes
P4.16	Start Delay-2	00:00 (mm:ss)	
P4.17	DC Brake Torque-2	20%	
P4.18	DC Brake Time-2	001 ms	
P4.19	Brake Curr Limit-2	250%	
P4.20	Soft Brake Delay-2	400 ms	
<b>5</b>	<b>Motor Protections</b>		
P5.1	Current Imbalance	30%	
P5.2	Current Imbal Delay	00:03 (mm:ss)	
P5.3	Current Imbal Action	Stop & Fault	
P5.4	Undercurrent	20%	
P5.5	Undercurrent Delay	00:05 (mm:ss)	
P5.6	Undercurrent Action	Stop & Fault	
P5.7	Overcurrent	400%	
P5.8	Overcurrent Delay	00:00 (mm:ss)	
P5.9	Overcurrent Action	Stop & Fault	
P5.10	Undervoltage	350 V	
P5.11	Undervoltage Delay	00:01 (mm:ss)	
P5.12	Undervoltage Action	Stop & Fault	
P5.13	Overvoltage	500 V	
P5.14	Overvolt Delay	00:01 (mm:ss)	
P5.15	Overvoltage Action	Stop & Fault	
P5.16	Underpower	10%	
P5.17	Underpower Delay	00:05 (mm:ss)	
P5.18	Underpower Action	Stop & Fault	
P5.19	Overpower	150%	
P5.20	Overpower Delay	00:05 (mm:ss)	
P5.21	Overpower Action	Stop & Fault	
P5.22	Excess Start Time	00:20 (mm:ss)	
P5.23	Ex. Start Time Action	Stop & Fault	
P5.24	Restart Delay	00:10 (mm:ss)	
P5.25	Starts Per Hour	4	
P5.26	Phase Sequence	Any Sequence	
P5.27	Maximum Frequency	55 Hz	
P5.28	Minimum Frequency	45 Hz	
P5.29	Frequency Delay	00:01 (mm:ss)	
P5.30	Frequency Action	Stop & Fault	
P5.31	Motor Overload	Stop & Fault	
<b>6</b>	<b>Starter Protections</b>		
P6.1	Auto Reset Count	1	
P6.2	Auto Reset Delay	00:05 (mm:ss)	
P6.3	Fieldbus Fault Action	Stop & Fault	
P6.4	Motor Therm Circuit	Stop & Fault	
P6.5	Shorted SCR Action	Fault	
<b>7</b>	<b>Digital Inputs</b>		
P7.1	Input 3 Function	Cmd Override: Terminal	
P7.2	Input 3 Fault	Motor Energized	
P7.3	Input 3 Fault Action	Stop & Fault	
P7.4	Input 3 Fault Delay	00:00 (mm:ss)	
P7.5	Input 3 Initial Delay	00:00 (mm:ss)	
P7.6	Input 3 Fault Name	External Fault Input 3	
P7.7	Input 4 Function	External Fault NO	

## 15.3 User parameter settings

	<b>Parameter Group</b>	<b>Default Setting</b>	<b>User Notes</b>
P7.8	Input 4 Fault	Motor Energized	
P7.9	Input 4 Fault Action	Stop & Fault	
P7.10	Input 4 Fault Delay	00:00 (mm:ss)	
P7.11	Input 4 Initial Delay	00:00 (mm:ss)	
P7.12	Input 4 Fault Name	External Fault Input 4	
P7.13	Enable/Reset Logic	Normally Closed NC	
<b>8</b>	<b>Relay Outputs</b>		
P8.1	Relay 2 Function	Bypassed	
P8.2	Relay 2 On Delay	00:00 (mm:ss)	
P8.3	Relay 2 Off Delay	00:00 (mm:ss)	
P8.4	Relay 3 Function	Fault	
P8.5	Relay 3 On Delay	00:00 (mm:ss)	
P8.6	Relay 3 Off Delay	00:00 (mm:ss)	
P8.7	Low Current Flag	50%	
P8.8	High Current Flag	100%	
P8.9	Motor Overload Flag	80%	
<b>9</b>	<b>Display</b>		
P9.1	Default Screen	Last Used	
P9.2	Screen Timeout	1 minute	
P9.3	Measurement Units	IEC (kW/°C)	
P9.4	Graph Data	Current	
P9.5	Graph Timebase	30 seconds	
P9.6	Graph Max Adjustment	400%	
P9.7	Graph Min Adjustment	0%	
P9.8	Keypad Param Lock	Read & Write	
P9.9	User Monitor 1	Current	
P9.10	User Monitor 2	Voltage	
P9.11	User Monitor 3	Mains Frequency	
P9.12	User Monitor 4	Motor pf	
P9.13	User Monitor 5	Motor Power	
P9.14	User Monitor 6	Motor Overload (%)	
<b>P10</b>	<b>Fieldbus</b>		
P10.1	Modbus RTU Address	1	
P10.2	Modbus RTU Baud	19200	
P10.3	Modbus RTU Parity	Even	
P10.4	Modbus RTU Timeout	Off	
P10.5	IP Address	192.168.001.011	
P10.6	Gateway Address	192.168.001.001	
P10.7	Subnet Mask	255.255.255.000	
P10.8	Fieldbus Select	Modbus RTU	
P10.9	Ext Network Timeout	Off	
<b>P20</b>	<b>Advanced</b>		
P20.1	PIN 1 Access Rights	Unlock Parameters	
P20.2	Set PIN 1	000000	
P20.3	PIN 2 Access Rights	PIN 2 Disabled	
P20.4	Set PIN 2	000000	
P20.5	Main Contactor Time	400 ms	
P20.6	Shunt Trip Mode	Disable	
P20.7	Remote LED Mode	Terminal Control	
P20.8	Current Calibration	100%	

## 15 Appendix

### 15.3 User parameter settings

	<b>Parameter Group</b>	<b>Default Setting</b>	<b>User Notes</b>
P20.9	Tracking Gain	50%	
P20.10	Pedestal Detect	80%	
P20.11	Fire Mode Enable	Disable	
P20.12	Model Rating	MR NOT SET	
P20.13	CT PCB Revision	0	
P20.14	Gate PCB Revision	0	
P20.15	Backplane PCB Rev	0	

Eaton is an intelligent power management company dedicated to protecting the environment and improving the quality of life for people everywhere. We make products for the data center, utility, industrial, commercial, machine building, residential, aerospace and mobility markets. We are guided by our commitment to do business right, to operate sustainably and to help our customers manage power – today and well into the future.

By capitalizing on the global growth trends of electrification and digitalization, we're accelerating the planet's transition to renewable energy sources, helping to solve the world's most urgent power management challenges, and building a more sustainable society for people today and generations to come.

For more information, visit [Eaton.com](https://www.eaton.com).